

The output signal from a photomultiplier tube can be directly input to the C9999 and it provides a voltage output signal with 50 Ω load at a conversion factor of 50 mV/μA. It can be used as a wide bandwidth amplifier not only for a photomultiplier tube but also for other detectors, or simply as a wide bandwidth amplifier.

FEATURES

- Bandwidth: DC to 10 MHz
- Current-to-voltage Conversion Factor:
50 mV/μA at 50 Ω load resistance
- Rise Time: 35 ns (Typ.)
- Non-inverting Output
- Compact · Light Weight

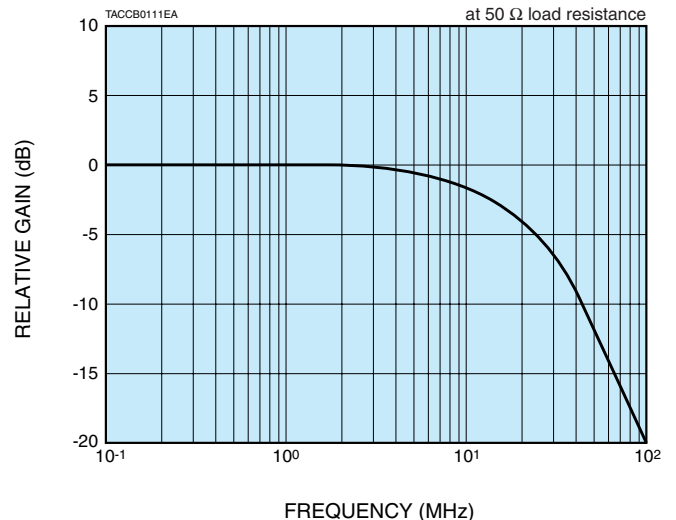
SPECIFICATIONS

Parameter		Description / Value
Frequency Bandwidth (-3 dB)		DC to 10 MHz
Voltage Gain ^(A)		43 dB ± 3 dB (Approx. 139 times)
Current-to-voltage Conversion Factor	Load Resistance: 1 MΩ	100 mV/μA
	Load Resistance: 50 Ω	50 mV/μA
Rise Time	Typ.	35 ns
Input Polarity		Positive / Negative
Amplifying Method		Non-inverting Output
Input Impedance		360 Ω
Recommended Load Resistance		50 Ω
Maximum Output Signal Voltage	Load Resistance: 1 MΩ	±3.2 V Min.
	Load Resistance: 50 Ω	±1.3 V Min.
Output Noise Voltage ^(A)	Typ.	2.2 mV rms
Connector	Input	BNC-R
	Output	BNC-R
	Power	DIN (6-pin)
Power Supply Voltage		±5 V
Max. Power Supply Voltage		±6.5 V
Power Supply Current	Max.	±70 mA
Operating Temperature		0 °C to +40 °C
Storage Temperature		-15 °C to +60 °C
Weight		Approx. 180 g

NOTE: ^(A)Load Resistance: 50 Ω

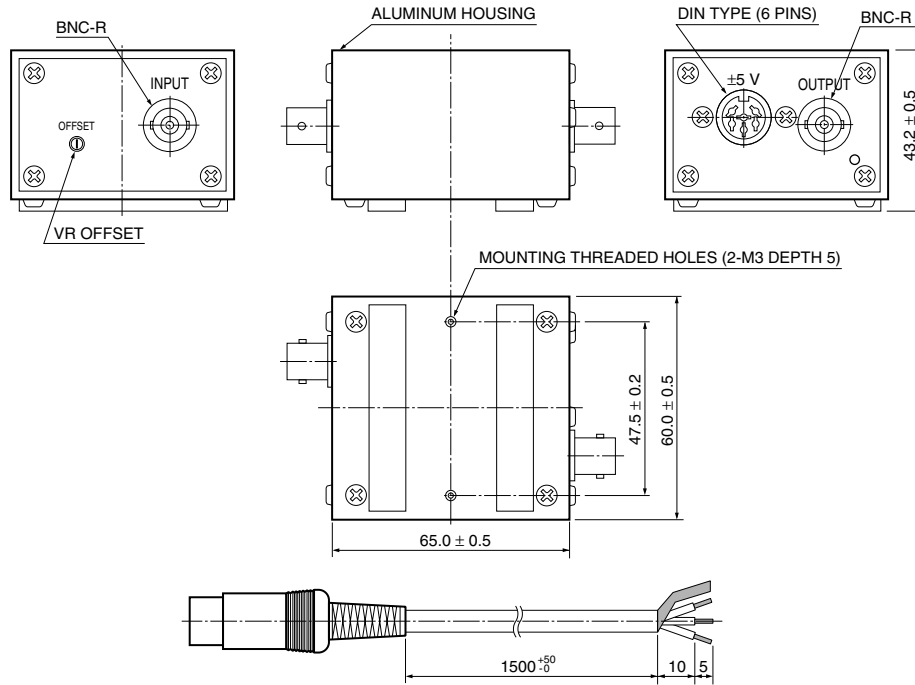


Figure 1: Typical Frequency Response



AMPLIFIER UNIT C9999

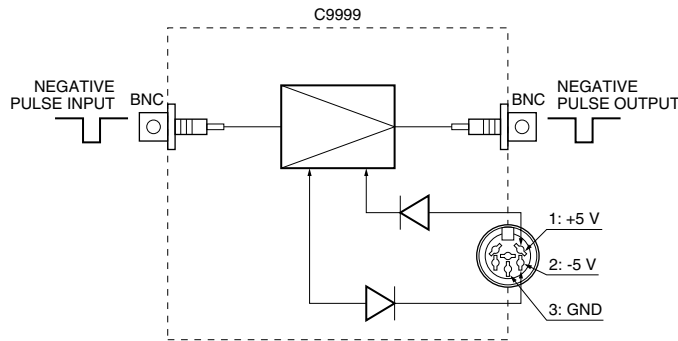
Figure 2: Dimensional Outlines (Unit: mm)



Power cable with connector (6 pin DIN type) is supplied with the C9999.

TACCA0262EC

Figure 3: Internal Connection Diagram



TACCC0144EA

CONNECTOR PIN	WIRE COLOR	CONNECTION
1	Red	+5 V
2	White	-5 V
3	Yellow	GND
4	—	—
5	—	—
6	—	—
External Conductor	Shield	GND

RELATED PRODUCTS

AMPLIFIER UNITS SELECTION GUIDE

Parameter	C7319	C9999	C6438	C6438-01	C9663	C11184	C5594
Frequency Bandwidth (-3 dB)	DC to 20 kHz or DC to 200 kHz (switchable)	DC to 10 MHz	DC to 50 MHz	DC to 50 MHz	DC to 150 MHz	DC to 300 MHz	50 kHz to 1.5 GHz
Current-to-Voltage Conversion Factor (Load Resistance: 50 Ω)	0.1 V/μA 1 V/μA, 10 V/μA (switchable)	50 mV/μA	0.5 mV/μA	25 mV/μA	4 mV/μA	1.25 mV/μA	3.15 mV/μA

Refer to the individual catalogs for detailed information.

HAMAMATSU PHOTONICS K.K. www.hamamatsu.com

HAMAMATSU PHOTONICS K.K., Electron Tube Division

314-5, Shimokanzo, Iwata City, Shizuoka Pref., 438-0193, Japan, Telephone: (81)539/62-5248, Fax: (81)539/62-2205

U.S.A.: Hamamatsu Corporation: 360 Foothill Road, P. O. Box 6910, Bridgewater, N.J. 08807-0910, U.S.A., Telephone: (1)908-231-0960, Fax: (1)908-231-1218 E-mail: usa@hamamatsu.com

Germany: Hamamatsu Photonics Deutschland GmbH: Arzbergerstr. 10, D-82211 Herrsching am Ammersee, Germany, Telephone: (49)8152-375-0, Fax: (49)8152-2658 E-mail: info@hamamatsu.de

France: Hamamatsu Photonics France S.A.R.L.: 19, Rue du Saule Trapu, Parc du Moulin de Massy, 91882 Massy Cedex, France, Telephone: (33)1 69 53 71 00, Fax: (33)1 69 53 71 10 E-mail: info@hamamatsu.fr

United Kingdom: Hamamatsu Photonics UK Limited: 2 Howard Court, 10 Tewin Road Welwyn Garden City Hertfordshire AL7 1BW, United Kingdom, Telephone: 44-(0)1707-294888, Fax: 44(0)1707-325777 E-mail: info@hamamatsu.co.uk

North Europe: Hamamatsu Photonics Norden AB: Smidesvägen 12, SE-171-41 SOLNA, Sweden, Telephone: (46)8-509-031-00, Fax: (46)8-509-031-01 E-mail: info@hamamatsu.se

Italy: Hamamatsu Photonics Italia: S.R.L.: Strada della Moia, 1/E, 20020 Arese, (Milano), Italy, Telephone: (39)02-935 81 733, Fax: (39)02-935 81 741 E-mail: info@hamamatsu.it

TACC1041E02
FEB. 2011. IP