

## S9227 series

### Video data rate: 5 MHz max., simultaneous charge integration

The S9227 series is a small CMOS linear image sensor designed for image input applications. Signal charge is integrated on all pixels simultaneously and then read out of 5 MHz. Two package styles are provided: a DIP type and a surface mount type.

#### Features

- Pixel pitch: 12.5  $\mu\text{m}$   
Pixel height: 250  $\mu\text{m}$
- 512 pixels
- 5 V single power supply operation
- Video data rate: 5 MHz max.
- Simultaneous charge integration
- Shutter function
- High sensitivity, low dark current, low noise
- Built-in timing generator allows operation with only start and clock pulse inputs.
- Spectral response range: 400 to 1000 nm
- Two package styles are provided:  
DIP (dual inline package) type: S9227-03  
Surface mount type: S9227-04

#### Applications

- Position detection
- Image reading

#### Structure

Parameter	Specification	Unit
Number of pixels	512	-
Pixel pitch	12.5	$\mu\text{m}$
Pixel height	250	$\mu\text{m}$
Photosensitive area length	6.4	mm
Package	Ceramic	-
Window material	Borosilicate glass (Tempax)	-

#### Absolute maximum ratings

Parameter	Symbol	Condition	Value	Unit
Supply voltage	Vdd	Ta=25 °C	-0.3 to +6	V
Clock pulse voltage	V(CLK)	Ta=25 °C	-0.3 to +6	V
Start pulse voltage	V(ST)	Ta=25 °C	-0.3 to +6	V
Operating temperature*1	Topr		-5 to +60	°C
Storage temperature*1	Tstg		-10 to +70	°C
Reflow soldering condition*2 *3	Tsol		Peak temperature 240 °C, 2 times (See P.7.)	-

Note: Exceeding the absolute maximum ratings even momentarily may cause a drop in product quality. Always be sure to use the product within the absolute maximum ratings.

\*1: No condensation

\*2: S9227-04

\*3: JEDEC level 5

**Recommended terminal voltage (Ta=25 °C)**

Parameter	Symbol	Min.	Typ.	Max.	Unit
Supply voltage	Vdd	4.75	5	5.25	V
Clock pulse voltage	High level	Vdd - 0.25	Vdd	Vdd + 0.25	V
	Low level	-	0	-	V
Start pulse voltage	High level	Vdd - 0.25	Vdd	Vdd + 0.25	V
	Low level	-	0	-	V

**Electrical characteristics [Ta=25 °C, Vdd=5 V, V(CLK)=V(ST)=5 V]**

Parameter	Symbol	Min.	Typ.	Max.	Unit
Clock pulse frequency	f(CLK)	50 k	-	5 M	Hz
Video data rate	VR	-	f(CLK)	-	Hz
Current consumption*4	I	20	26	32	mA
Conversion efficiency	CE	-	1.6	-	μV/e <sup>-</sup>
Output impedance*5	Zo	-	50	200	Ω

\*4: f(CLK)=5 MHz

\*5: An increased current consumption at the video output terminal rises the sensor chip temperature causing an increased dark current. Connect a buffer amplifier for impedance conversion to the video output terminal so that the current flow is minimized. Use a JFET or CMOS input, high-impedance input op amp as the buffer amplifier.

**Electrical and optical characteristics [Ta=25 °C, Vdd=5 V, V(CLK)=V(ST)=5 V, f(CLK)=5 MHz]**

Parameter	Symbol	Min.	Typ.	Max.	Unit
Spectral response range	λ	400 to 1000			nm
Peak sensitivity wavelength	λp	-	650	-	nm
Dark current	ID	-	10	100	fA
Saturation charge	Qsat	400	430	-	fC
Dark output voltage*6	Vd	-	1	10	mV
Saturation output voltage*7	Vsat	4	4.3	-	V
Readout noise*8	Nr	-	0.45	2	mV rms
Output offset voltage	Vo	-	0.6	0.9	V
Photoresponse nonuniformity*9 *10	PRNU	-	-	±5	%

\*6: Integration time=10 ms

\*7: Voltage difference with respect to Vo

\*8: Dark state

\*9: Photoresponse nonuniformity (PRNU) is the output nonuniformity that occurs when the entire photosensitive area is uniformly illuminated by light which is 50% of the saturation exposure level. PRNU is measured using 510 pixels excluding the pixels at both ends, and is defined as follows:

$$PRNU = \frac{\Delta X}{X} \times 100 (\%)$$

X: average output of all pixels, ΔX: difference between X and maximum or minimum output

\*10: Measured with a tungsten lamp of 2856 K

**Block diagram**

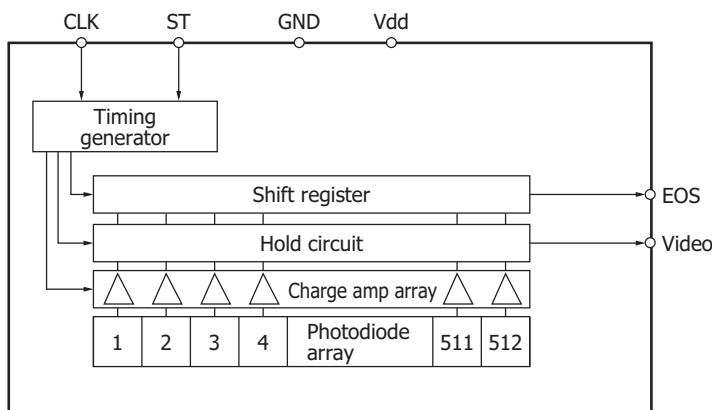

KMPDC0167EB

**Spectral response (typical example)**

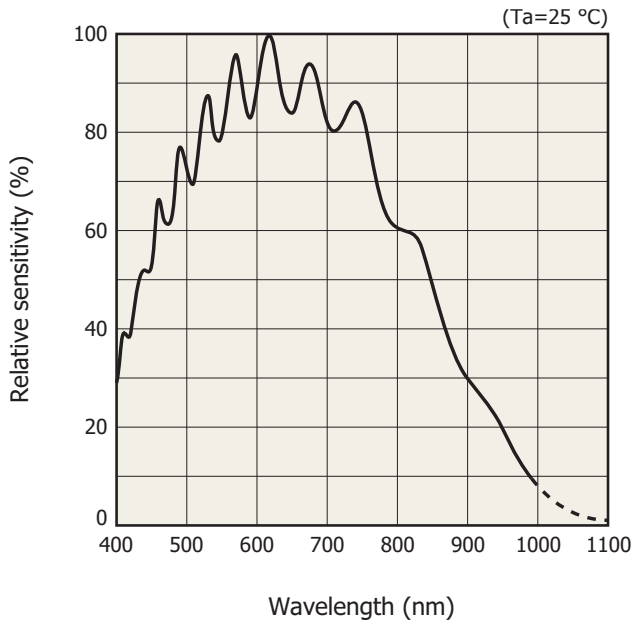

KMPDB0230EC

**Resolution**

**CTF: contrast transfer function**

$$CTF = \frac{V_{WO} - V_{BO}}{V_W - V_B}$$

- V<sub>WO</sub> : output white level
- V<sub>BO</sub> : output black level
- V<sub>W</sub> : output white level (when input pattern pulse width is wide)
- V<sub>B</sub> : output black level (when input pattern pulse width is wide)

**Contrast transfer function vs. spatial frequency (typical example)**

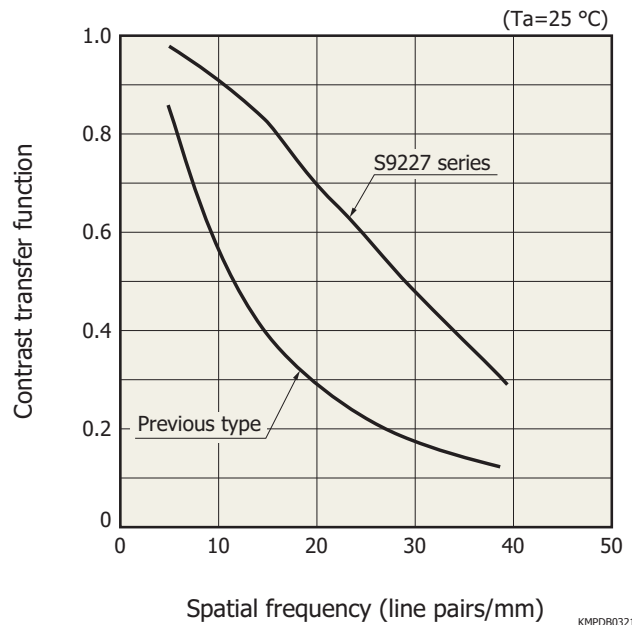

KMPDB0321EB

Dark output voltage vs. temperature (typical example)

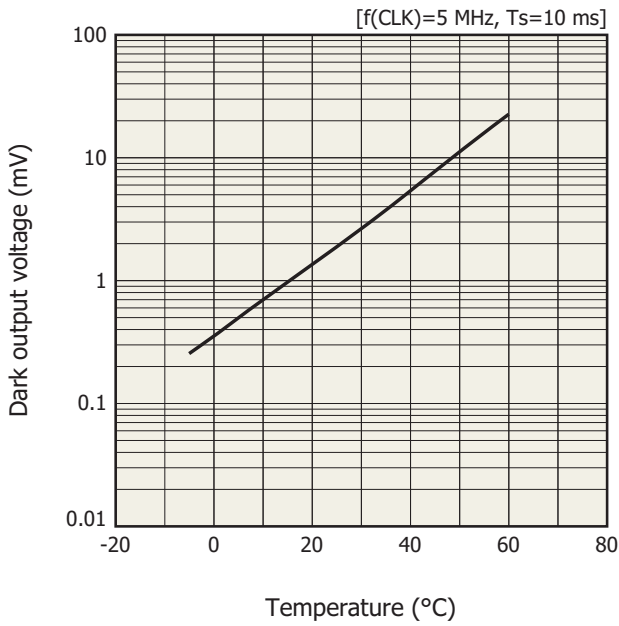

KMPDB0322EC

Current consumption vs. temperature (typical example)

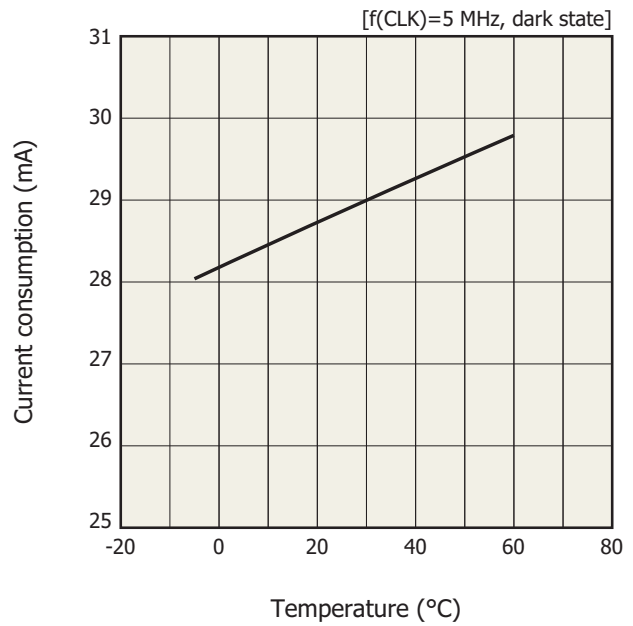

KMPDB0323EC

Output waveform of one element

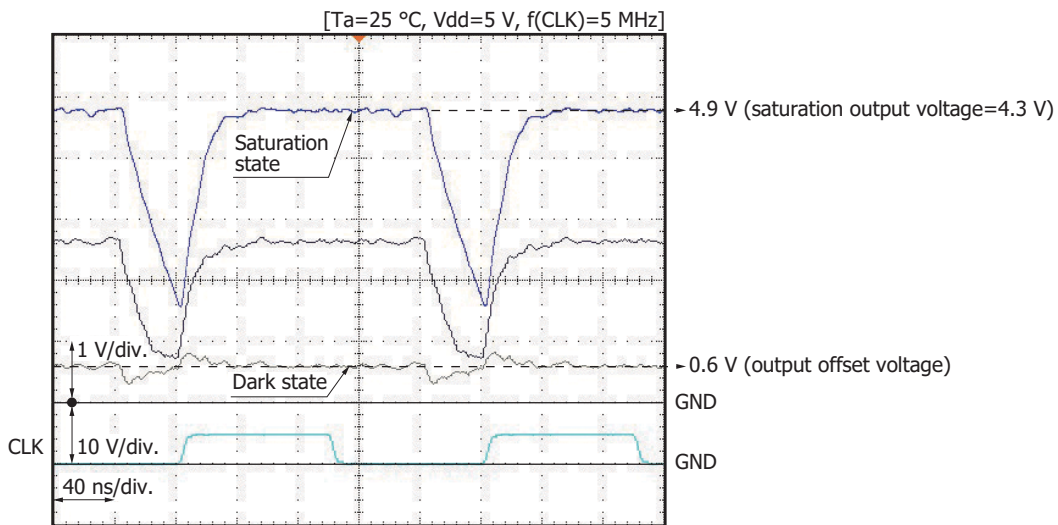

**Timing chart**

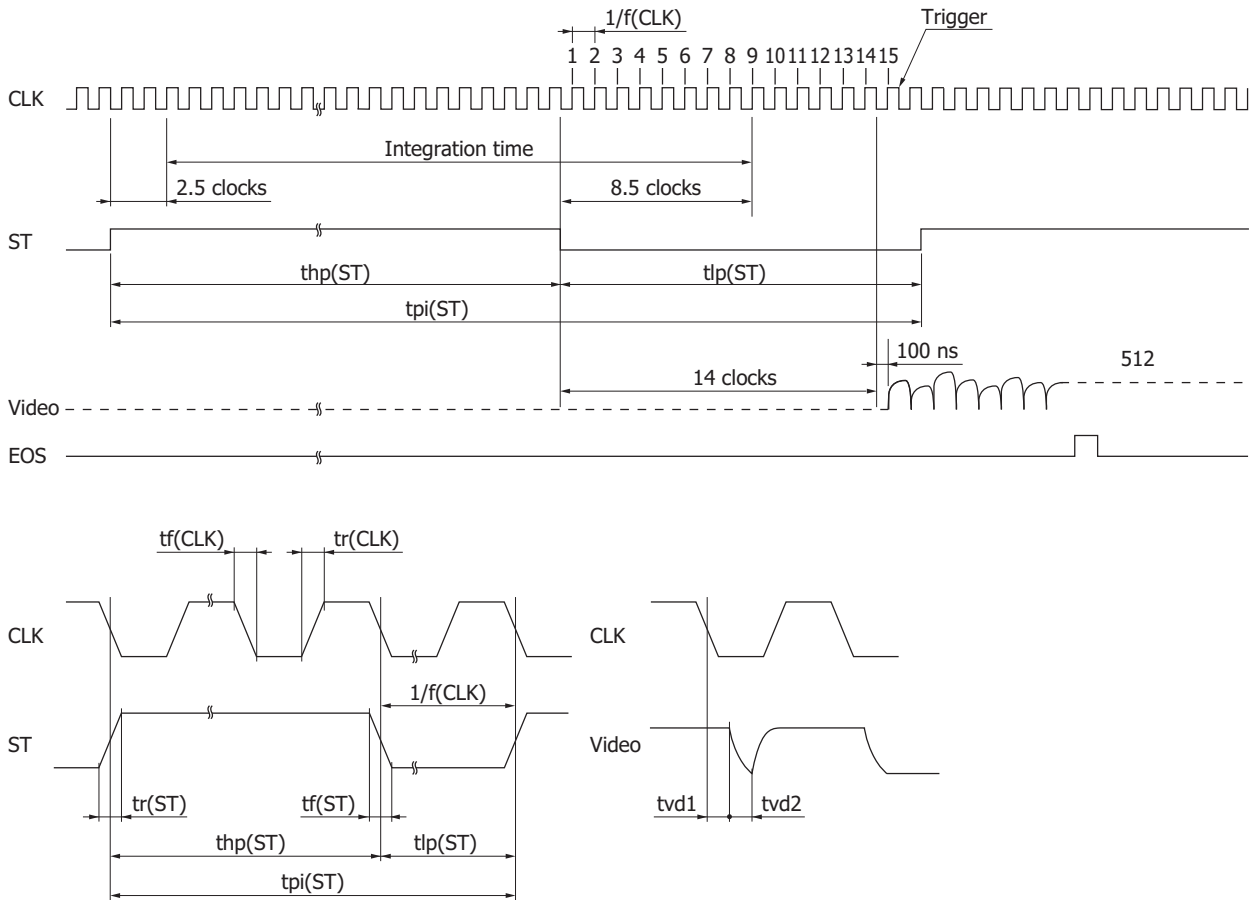

KMPDC0166EF

Parameter	Symbol	Min.	Typ.	Max.	Unit
Start pulse cycle	tpi(ST)	530/f(CLK)	-	1100 m	s
Start pulse high period	thp(ST)	8/f(CLK)	-	1000 m	s
Start pulse low period	tlp(ST)	15/f(CLK)	-	100 m	s
Start pulse rise and fall times	tr(ST), tf(ST)	0	20	30	ns
Clock pulse duty ratio	-	45	50	55	%
Clock pulse rise and fall times	tr(CLK), tf(CLK)	0	20	30	ns
Video delay time 1	tvd1	32	40	48	ns
Video delay time 2	tvd2	40	50	60	ns

Note: The internal timing circuit starts operating at the rise of CLK pulse immediately after ST pulse sets to low.

The integration time equals the high period of ST pulse plus 6 CLK cycles.

The output from 1st channel appears 14 clocks plus 100 ns after the falling edge of ST pulse.

The EOS pulse is output 39 ns after the falling edge of CLK pulse.

The output voltage after reading the last pixel (512 ch) is indefinite.

The integration time can be changed by changing the high-to-low ratio of ST pulses.

Start pulse setting example (for setting the start pulse cycle to a minimum and the integration time to a maximum)

Start pulse high period=515/f(CLK), Start pulse low period=15/f(CLK)

Dimensional outlines (unit: mm)

S9227-03

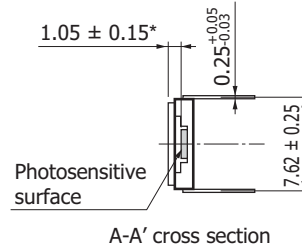
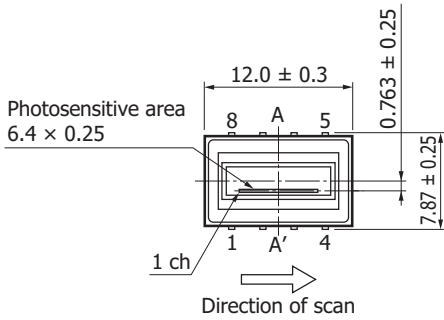

\* Distance from upper surface of window to photosensitive surface

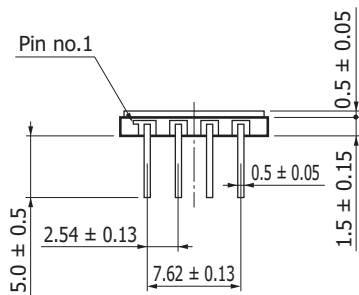

Pin no.	Symbol	I/O	Pin name
1	GND		Ground
2	NC		No connection
3	NC		No connection
4	Vdd	I	Supply voltage
5	Video	O	Video output
6	EOS	O	End of scan
7	ST	I	Start pulse
8	CLK	I	Clock pulse

KMPDA0173EF

S9227-04

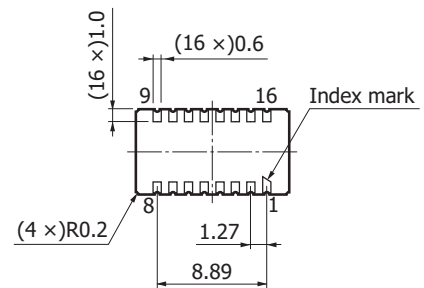
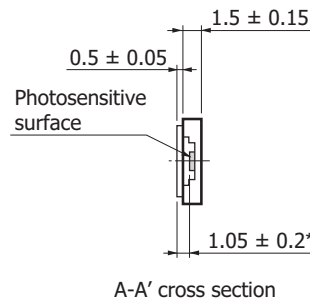
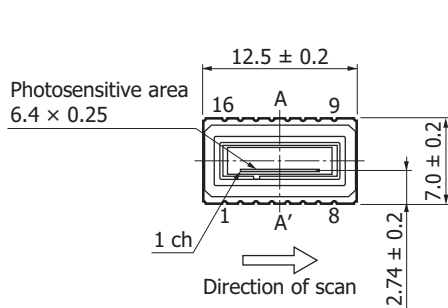

\* Distance from upper surface of window to photosensitive surface

KMPDA0281EC

Pin no.	Symbol	I/O	Pin name	Pin no.	Symbol	I/O	Pin name
1	NC		No connection	9	NC		No connection
2	NC		No connection	10	NC		No connection
3	GND		Ground	11	Video	O	Video output
4	NC		No connection	12	EOS	O	End of scan
5	NC		No connection	13	ST	I	Start pulse
6	Vdd	I	Supply voltage	14	CLK	I	Clock pulse
7	NC		No connection	15	NC		No connection
8	NC		No connection	16	NC		No connection

## Precautions

### (1) Electrostatic countermeasures

This device has a built-in protection circuit against static electrical charges. However, to prevent destroying the device with electrostatic charges, take countermeasures such as grounding yourself, the workbench and tools to prevent static discharges. Also protect this device from surge voltages which might be caused by peripheral equipment.

### (2) Light input window

If the incident window is contaminated or scratched, the output uniformity will deteriorate considerably, so care should be taken in handling the window. Avoid touching it with bare hands.

The window surface should be cleaned before using the device. If dry cloth or dry cotton swab is used to rub the window surface, static electricity may be generated, and therefore this practice should be avoided. Use soft cloth, cotton swab or soft paper moistened with ethyl alcohol to wipe off dirt and foreign matter on the window surface.

### (3) Soldering

To prevent damaging the device during soldering, take precautions to prevent excessive soldering temperatures and times. Soldering should be performed within 5 seconds at a soldering temperature below 260 °C.

### (4) Reflow soldering (S9227-04)

Soldering conditions may differ depending on the board size, reflow furnace, etc. Check the conditions before soldering. A sudden temperature rise and cooling may be the cause of trouble, so make sure that the temperature change is within 4 °C per second.

The bonding portion between the ceramic base and the glass may discolor after reflow soldering, but this has no adverse effects on the hermetic sealing of the product.

### (5) Operating and storage environments

Handle the device within the temperature range specified in the absolute maximum ratings. Operating or storing the device at an excessively high temperature and humidity may cause variations in performance characteristics and must be avoided.

### (6) UV exposure

This product is not designed to prevent deterioration of characteristics caused by UV exposure, so do not expose it to UV light.

## Recommended temperature profile of reflow soldering (S9227-04)

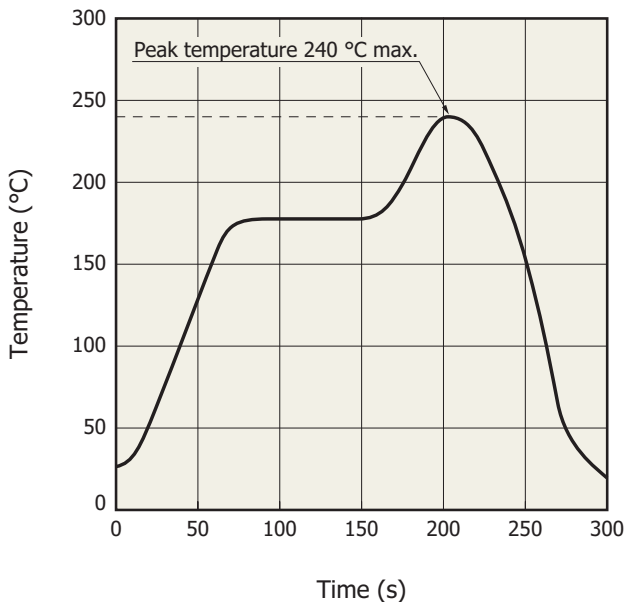

KAPDB0169EA

### Application circuit example (S9227-03)\*11

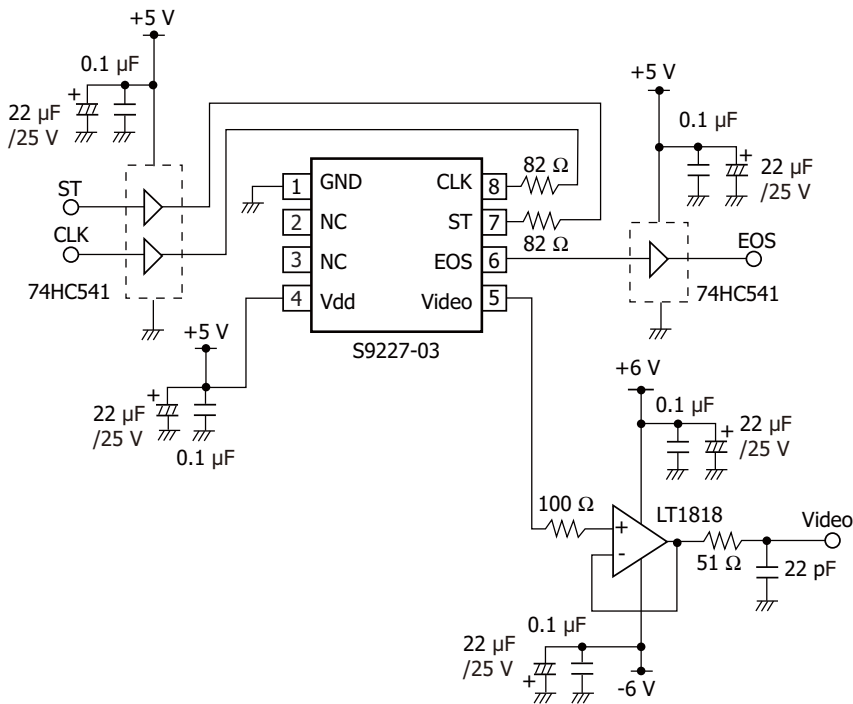

KMPDC0415EA

\*11: The S9227-04 has a different pin connections, but uses the same circuit.

### Related information

[www.hamamatsu.com/sp/ssd/doc\\_en.html](http://www.hamamatsu.com/sp/ssd/doc_en.html)

#### Precautions

- Notice
- Image sensors/Precautions
- Surface mount type products/Precautions

Information described in this material is current as of January, 2014.

Product specifications are subject to change without prior notice due to improvements or other reasons. This document has been carefully prepared and the information contained is believed to be accurate. In rare cases, however, there may be inaccuracies such as text errors. Before using these products, always contact us for the delivery specification sheet to check the latest specifications.

The product warranty is valid for one year after delivery and is limited to product repair or replacement for defects discovered and reported to us within that one year period. However, even if within the warranty period we accept absolutely no liability for any loss caused by natural disasters or improper product use.

Copying or reprinting the contents described in this material in whole or in part is prohibited without our prior permission.

# HAMAMATSU

[www.hamamatsu.com](http://www.hamamatsu.com)

HAMAMATSU PHOTONICS K.K., Solid State Division

1126-1 Ichino-cho, Higashi-ku, Hamamatsu City, 435-8558 Japan, Telephone: (81) 53-434-3311, Fax: (81) 53-434-5184

U.S.A.: Hamamatsu Corporation: 360 Foothill Road, P.O.Box 6910, Bridgewater, N.J. 08807-0910, U.S.A., Telephone: (1) 908-231-0960, Fax: (1) 908-231-1218

Germany: Hamamatsu Photonics Deutschland GmbH: Arzbergerstr. 10, D-82211 Herrsching am Ammersee, Germany, Telephone: (49) 8152-375-0, Fax: (49) 8152-265-8

France: Hamamatsu Photonics France S.A.R.L.: 19, Rue du Saule Trapu, Parc du Moulin de Massy, 91882 Massy Cedex, France, Telephone: 33-(1) 69 53 71 00, Fax: 33-(1) 69 53 71 10

United Kingdom: Hamamatsu Photonics UK Limited: 2 Howard Court, 10 Tewin Road, Welwyn Garden City, Hertfordshire AL7 1BW, United Kingdom, Telephone: (44) 1707-294888, Fax: (44) 1707-325777

North Europe: Hamamatsu Photonics Norden AB: Thorshamnsgatan 35 16440 Kista, Sweden, Telephone: (46) 8-509-031-00, Fax: (46) 8-509-031-01

Italy: Hamamatsu Photonics Italia S.R.L.: Strada della Moia, 1 int. 6, 20020 Arese, (Milano), Italy, Telephone: (39) 02-935-81-733, Fax: (39) 02-935-81-741

China: Hamamatsu Photonics (China) Co., Ltd.: 1201 Tower B, Jiaming Center, No.27 Dongsanhuan Beilu, Chaoyang District, Beijing 100020, China, Telephone: (86) 10-6586-6006, Fax: (86) 10-6586-2866