

■ **Features**

- Lateral multimode (broad stripe)
- Radiant output power (CW): 1 W
- Peak emission wavelength: 830 nm
- Emitting area size: 50 μm × 10 μm

■ **Applications**

- Pumping source for solid state laser
- Processing
- Medical instrument
- Measure instrument



■ **Absolute maximum ratings (T<sub>op(c)</sub> = 25 °C)**

Parameter	Symbol	Value	Unit
Radiant output power	Φ <sub>e</sub>	1.2	W
Forward current	I <sub>f</sub>	1.4	A
Reverse voltage	V <sub>r</sub>	2	V
Operating temperature	T <sub>op(c)</sub>	0 to +30	°C
Storage temperature	T <sub>stg</sub>	-30 to +80	°C

■ **Electrical and optical characteristics (T<sub>op(c)</sub> = 25 °C)**

Parameter	Symbol	Conditions	Value			Unit	
			Min.	Typ.	Max.		
Radiant output power	Φ <sub>e</sub>	I <sub>f</sub> = 1.2 A	—	1	—	W	
Forward current	I <sub>op</sub>	Φ <sub>e</sub> = 1 W	—	1.2	—	A	
Peak emission wavelength	λ <sub>c</sub>		—	830	—	nm	
Spectral radiation half bandwidth	Δλ		—	2	—	nm	
Forward voltage	V <sub>op</sub>		—	2	—	V	
Beam spread angle	Parallel	θ <sub>//</sub>	Φ <sub>e</sub> = 1 W FWHM	—	8	—	degree
	Vertical	θ <sub>⊥</sub>		—	32	—	degree
Emitting area	—	Value at designing	—	50 × 1	—	μm	
Lasing threshold current	I <sub>th</sub>	—	—	0.35	—	A	

# CW Laser Diode L9277 Series

Figure 1: Radiant output power vs. Forward current (typ.)

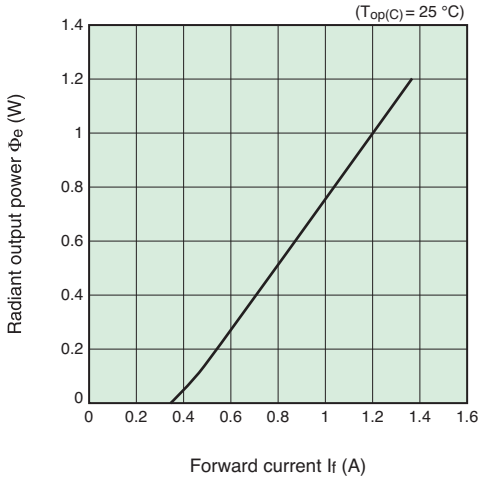

Figure 2: Typical emission spectrum

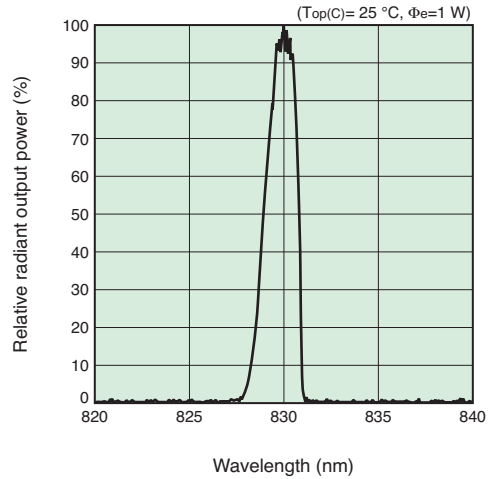

Figure 3: Directivity (typ.)

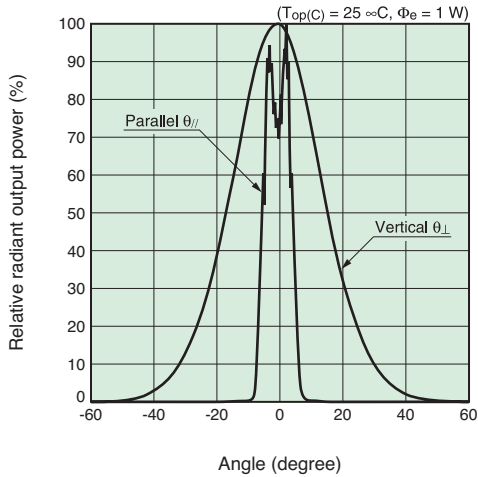
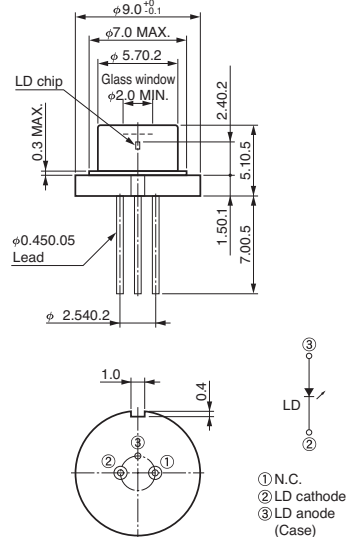
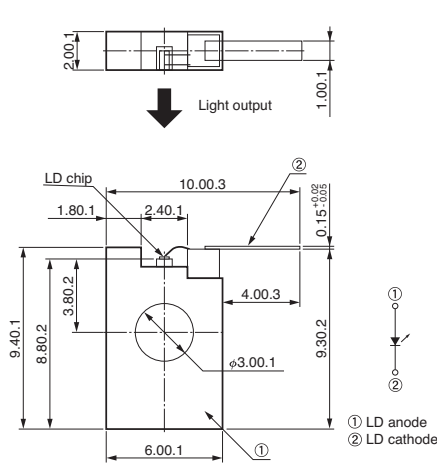

Figure 4: Dimensional outline (unit: mm)

● L9277-42  
Φ9.0CD



● L9277-62  
Side Out OHS



● L9277-72  
Head Out OHS

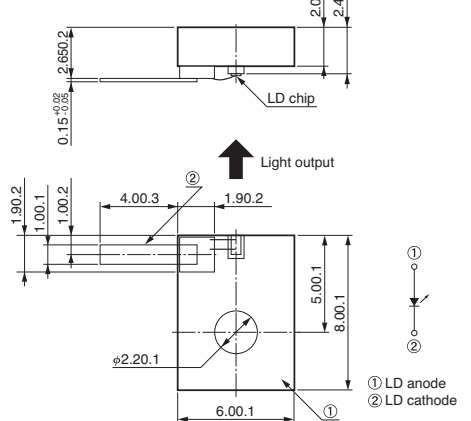

**HAMAMATSU PHOTONICS K.K.** [www.hamamatsu.com](http://www.hamamatsu.com)

**HAMAMATSU PHOTONICS K.K., Laser Group, Sales Dept.**

1-8-3, Shinmiyakoda, Kita-ku, Hamamatsu City, Shizuoka, 431-2103, Japan, Telephone: (81)53-484-1301, Fax: (81)53-484-1302, E-mail: laser-g@lsh.hpk.co.jp

U.S.A.: Hamamatsu Corporation: 360 Foothill Road, Bridgewater, NJ 08807, U.S.A., Telephone: (1)908-231-0960, Fax: (1)908-231-1218 E-mail: usa@hamamatsu.com

Germany: Hamamatsu Photonics Deutschland GmbH.: Arzbergerstr. 10, D-82211 Herrsching am Ammersee, Germany, Telephone: (49)8152-375-0, Fax: (49)8152-265-8 E-mail: info@hamamatsu.de

France: Hamamatsu Photonics France S.A.R.L.: 19, Rue du Saule Trapu, Parc du Moulin de Massy, 91882 Massy Cedex, France, Telephone: (33)1 69 53 71 00, Fax: (33)1 69 53 71 10 E-mail: infos@hamamatsu.fr

United Kingdom: Hamamatsu Photonics UK Limited: 2 Howard Court, 10 Tewin Road, Welwyn Garden City, Hertfordshire AL7 1BW, UK, Telephone: (44)1707-294888, Fax: (44)1707-325777 E-mail: info@hamamatsu.co.uk

North Europe: Hamamatsu Photonics Norden AB: Torshamnsgatan 35 16440 Kista, Sweden, Telephone: (46)8-509-031-00, Fax: (46)8-509-031-01 E-mail: info@hamamatsu.se

Italy: Hamamatsu Photonics Italia S.r.l.: Strada della Moia, 1 int. 6, 20020 Arese (Milano), Italy, Telephone: (39)02-935-81-733, Fax: (39)02-935-81-741 E-mail: info@hamamatsu.it

China: Hamamatsu Photonics (China) Co., Ltd.: 1201 Tower B, Jiaming Center, 27 Dongsanhuan Beilu, Chaoyang District, 100020 Beijing, China, Telephone: (86)10-6586-6006, Fax: (86)10-6586-2866 E-mail: hpc@hamamatsu.com.cn

Taiwan: Hamamatsu Photonics Taiwan Co., Ltd.: 8F-3, No.158, Section2, Gongdao 5th Road, East District, Hsinchu, 300, Taiwan R.O.C. Telephone: (886)03-659-0080, Fax: (886)07-811-7238 E-mail: info@tw.hpk.co.jp