

# Transmitter/Receiver photo IC for optical link

L10063-01, S10064-01B

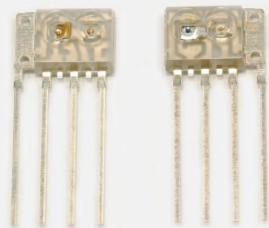

## For MOST automotive network, 50 Mbps band POF communications

The L10063-01 and S10064-01B are transmitter and receiver photo ICs developed for MOST (Media Oriented System Transport) networks used in vehicles to communicate multimedia information. The transmitter photo IC L10063-01 consists of a red LED and driver IC incorporated into a clear plastic package and can be set to an operating mode that reduces the optical output level by half. The receiver photo IC S10064-01B is a monolithic photo IC fabricated by the PiN-BiP process and features a wide dynamic range. It also has a low power consumption "sleeping mode" and an optical wakeup mode triggered by input of light. Both the transmitter and receiver photo IC input or output digital signals through a TTL interface.

### Features

L10063-01

- Wide operating temperature range: -40 to +105 °C
- DC to 50 Mbps data communications
- TTL input
- Optical output 50 % cut mode

S10064-01B

- Wide operating temperature range: -40 to +105 °C
- 4 M to 50 Mbps data communications
- Monolithic structure immune from external noise
- TTL output
- Wide dynamic range
- Sleeping mode with optical wakeup

### Applications

#### → Only for vehicle networks (MOST)

MOST compliant products

Specifications of these products are subject to change without prior notice to keep up with changes in the MOST standard.

### ▣ Absolute maximum ratings\*1 (Ta= -40 to +105 °C)

Parameter	Symbol	L10063-01, S10064-01B	Unit
Supply voltage	Vcc	-0.5 to +7.0	V
Operating temperature	Topr	-40 to +105	°C
Storage temperature	Tstg	-40 to +120	°C
Soldering	Tsol	260 °C, 5 s, 3 times, at least 2.5 mm away from lead root	-

\*1: A bypass capacitor (0.1 μF) is connected between Vcc and GND at a position within 3 mm from the lead, and a 10 μF capacitor is also connected to the power supply line nearby.

The center of the optical fiber is aligned with the center of the package lens.

The distance between the fiber end and the lens top is 0.1 mm.

Note: Exceeding the absolute maximum ratings even momentarily may cause a drop in product quality. Always be sure to use the product within the absolute maximum ratings.

S10064-01B

Electrical and optical characteristics (Ta=-40 to +105 °C, Vcc=4.75 to 5.25 V \*1)

Parameter	Symbol	Condition	Min.	Typ.	Max.	Unit
Current consumption (operation mode)	Icco	*2	-	-	30	mA
Current consumption (sleeping mode)	Iccs	Dark state	-	-	20	μA
Receiver level	Popt3	Bi-phase signal	-25	-	-2	dBm
Vout	High level output voltage	Ioh= -150 μm	2.5	-	Vcc+0.3	V
	Low level output voltage	Iol=1.6 mA	0	-	0.4	V
	Rise time	*2 *3 10 to 90%	-	-	9	ns
	Fall time		-	-	7	
Pulse width variation	tpwv	*2 *3 *4 *6	17.9	-	29.79	ns
Pulse width distortion (average value)	tapwd	*2 *3 *4 *6	-2.69	-	+6.49	ns
Operation to sleeping mode transition receivable level	Ps1	*2 *5	-39	-	-25.5	dBm
Sleeping mode to operation transition receivable level	Pop					
Mode output	High level voltage	Vmh	Imh=-20 μA	4.0	-	V
	Low level voltage	Vml	Iml=0.88 mA	-	-	0.5

\*1: A bypass capacitor (0.1 μF) is connected between Vcc and GND at a position within 3 mm from the lead, and a 10 μF capacitor is also connected to the power supply line nearby.

The center of the optical fiber is aligned with the center of the package lens.

The distance between the fiber end and the lens top is 0.1 mm.

\*2: Measured with input signals conforming to SP3 MOST specification of physical layer Rev 1.1 Addendum B

\*3: Measured with RL=50 kΩ, CL=15 pF (including parasitic capacitance such as probe, connector and evaluation circuit board pattern), and threshold voltage 1.5 V

\*4: An optical input waveform is generated with a Hamamatsu standard transmitter.

\*5: Average optical output is measured with a POF (NA=0.5).

\*6: Measured with BiPhase PRBS at 45.2 Mbps (NRZ signal conversion)

Note: If modulated light at 4 Mbps or less (including DC light and no light input) is input to S10064-01B, the high and low levels cannot be discerned.

Mode output waveform

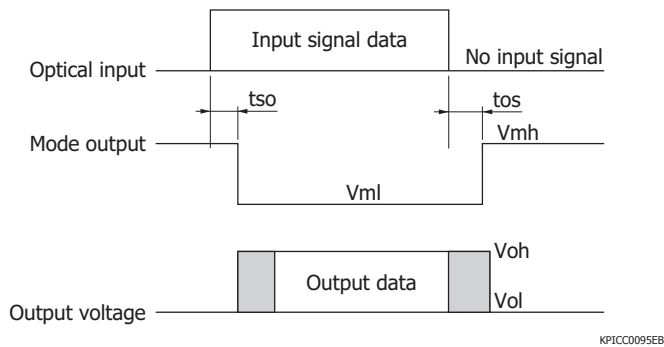

Output waveform example

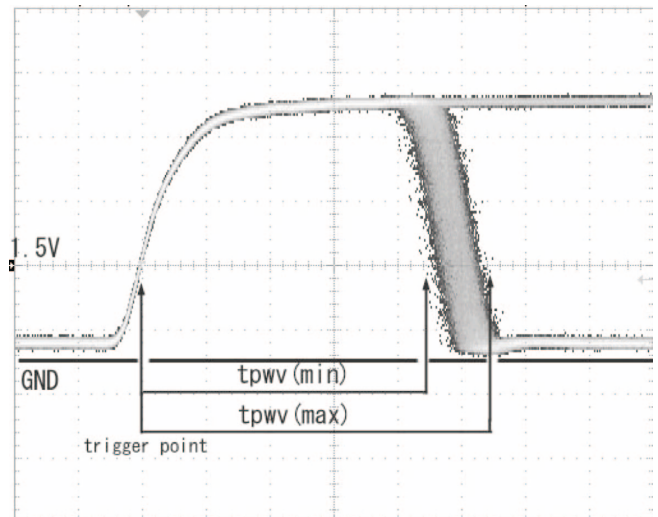

Vertical axis: 1 V/div., Horizontal axis: 5 ns/div.  
 (Ta=25 °C, Vcc=5.25 V, Pi=-26 dBm,  
 RL=50 kΩ, CL=15 pF, 45.2 Mbps)

L10063-01

Electrical and optical characteristics (Ta=-40 to +105 °C, Vcc= 4.75 to 5.25 V<sup>\*7</sup>)

Parameter	Symbol	Condition	Min.	Typ.	Max.	Unit
Current consumption	I <sub>cc</sub>	V <sub>in</sub> = 2.0 V, R <sub>cont</sub> =13.5 kΩ	-	-	40	mA
Peak emission wavelength	λ <sub>p</sub>		630	650	670	nm
Spectral half width (FWHM)	Δλ		-	20	30	nm
Fiber coupled optical output 1	Po1	*8 *9 R <sub>cont</sub> =13.5 kΩ	-9	-	-2	dBm
Fiber coupled optical output 2	Po2	*8 *9 R <sub>cont</sub> =27 kΩ	-12.5	-	-4.5	dBm
Extinction ratio	re		10	-	-	dB
Rise time at pulse drive	t <sub>r</sub>	*8 20 to 80%	-	-	6.0	ns
Fall time at pulse drive	t <sub>f</sub>	*8 80 to 20%	-	-	6.0	ns
Pulse width variation	tp <sub>wv</sub>	*8 *10 50%	19.99	-	24.29	ns
Pulse width distortion (average value)	tap <sub>wd</sub>	*8 *10 50%	-1.39	-	+1.39	ns

\*7: A bypass capacitor (0.1 μF) connected between Vcc and GND at a position within 3 mm from the lead, and a 10 μF capacitor is also connected to the power supply line nearby.

The center of the optical fiber is aligned with the center of the package lens.  
The distance between the fiber end and the lens top is 0.1 mm.

\*8: Measured with input signals conforming to SP1 MOST specification of physical layer Rev 1.1 Addendum B.

\*9: Average value measured with a plastic fiber (φ1 mm, SI-POF, NA=0.5, 1 m) made by Mitsubishi Rayon.

\*10: Measured with BiPhase PRBS at 45.2 Mbps (NRZ signal conversion).

Dimensional outlines (unit: mm)

L10063-01

S10064-01B

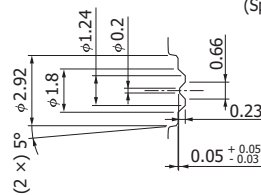
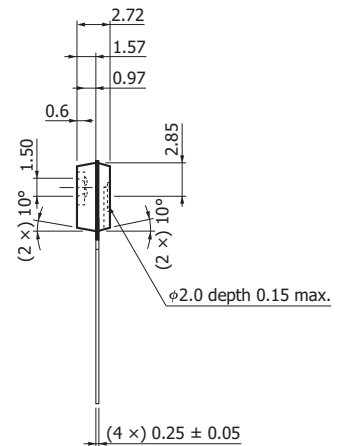
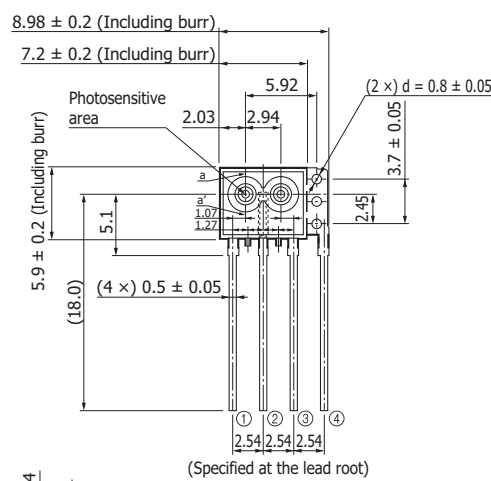
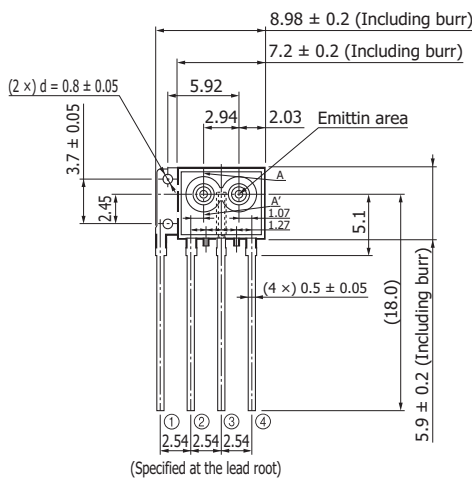

A-A' Cross section

Tolerance unless otherwise noted: ±0.1, ±2°  
R0.3 max.  
Values in parentheses indicate reference value.  
Lead surface finish: Pd plating  
Shaded area indicates burr.

Pin no.	L10063-01	S10064-01B
①	V <sub>IN</sub>	V <sub>CC</sub>
②	GND	GND
③	V <sub>CC</sub>	MODEOUT
④	Cont	V <sub>out</sub>

KPIC0067EC

## Related information

[www.hamamatsu.com/sp/ssd/doc\\_en.html](http://www.hamamatsu.com/sp/ssd/doc_en.html)

### ■ Precautions

- Disclaimer
- Metal, ceramic, plastic products

Information described in this material is current as of October 2017.

Product specifications are subject to change without prior notice due to improvements or other reasons. This document has been carefully prepared and the information contained is believed to be accurate. In rare cases, however, there may be inaccuracies such as text errors. Before using these products, always contact us for the delivery specification sheet to check the latest specifications.

The product warranty is valid for one year after delivery and is limited to product repair or replacement for defects discovered and reported to us within that one year period. However, even if within the warranty period we accept absolutely no liability for any loss caused by natural disasters or improper product use. Copying or reprinting the contents described in this material in whole or in part is prohibited without our prior permission.

# HAMAMATSU

[www.hamamatsu.com](http://www.hamamatsu.com)

HAMAMATSU PHOTONICS K.K., Solid State Division

1126-1 Ichino-cho, Higashi-ku, Hamamatsu City, 435-8558 Japan, Telephone: (81) 53-434-3311, Fax: (81) 53-434-5184

U.S.A.: Hamamatsu Corporation: 360 Foothill Road, Bridgewater, N.J. 08807, U.S.A., Telephone: (1) 908-231-0960, Fax: (1) 908-231-1218, E-mail: [usa@hamamatsu.com](mailto:usa@hamamatsu.com)

Germany: Hamamatsu Photonics Deutschland GmbH: Arzbergerstr. 10, D-82211 Herrsching am Ammersee, Germany, Telephone: (49) 8152-375-0, Fax: (49) 8152-265-8, E-mail: [info@hamamatsu.de](mailto:info@hamamatsu.de)

France: Hamamatsu Photonics France S.A.R.L.: 19, Rue du Saule Trapu, Parc du Moulin de Massy, 91882 Massy Cedex, France, Telephone: 33-(1) 69 53 71 00, Fax: 33-(1) 69 53 71 10, E-mail: [infos@hamamatsu.fr](mailto:infos@hamamatsu.fr)

United Kingdom: Hamamatsu Photonics UK Limited: 2 Howard Court, 10 Tewin Road, Welwyn Garden City, Hertfordshire AL7 1BW, United Kingdom, Telephone: (44) 1707-294888, Fax: (44) 1707-325777, E-mail: [info@hamamatsu.co.uk](mailto:info@hamamatsu.co.uk)

North Europe: Hamamatsu Photonics Norden AB: Torshamnsgatan 35 16440 Kista, Sweden, Telephone: (46)8-509 031 00, Fax: (46)8-509 031 01, E-mail: [info@hamamatsu.se](mailto:info@hamamatsu.se)

Italy: Hamamatsu Photonics Italia S.r.l.: Strada della Moia, 1 int. 6, 20020 Arese (Milano), Italy, Telephone: (39)02-93 58 17 33, Fax: (39)02-93 58 17 41, E-mail: [info@hamamatsu.it](mailto:info@hamamatsu.it)

China: Hamamatsu Photonics (China) Co., Ltd.: B1201, Jiaming Center, No.27 Dongsanhuan Beilu, Chaoyang District, Beijing 100020, China, Telephone: (86) 10-6586-6006, Fax: (86) 10-6586-2866, E-mail: [hpc@hamamatsu.com.cn](mailto:hpc@hamamatsu.com.cn)

Taiwan: Hamamatsu Photonics Taiwan Co., Ltd.: 8F-3, No. 158, Section2, Gongdao 5th Road, East District, Hsinchu, 300, Taiwan R.O.C. Telephone: (886)03-659-0080, Fax: (886)03-659-0081, E-mail: [info@tw.hpj.co.jp](mailto:info@tw.hpj.co.jp)