

MPPC® (multi-pixel photon counter)

S12572-010, -015C/P

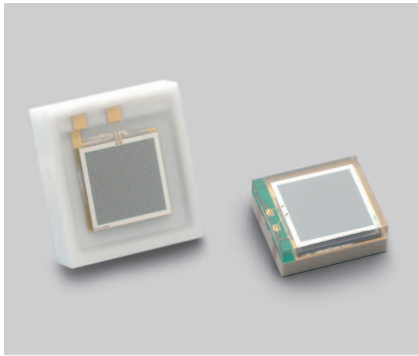

**Low afterpulse, wide dynamic range,
for high-speed measurement**
Photosensitive area: 3 × 3 mm

These MPPCs utilize very small pixels arrayed at high densities to achieve a high-speed recovery time and wide dynamic range. Hamamatsu currently produces MPPC with a pixel density up to 10000 pixels/mm² (pixel pitch: 10 μm). Utilizing advanced technology to enhance photon detection efficiency minimizes the drop in photon detection efficiency that usually occurs due to shrinking the pixel pitch.

Features

- Low afterpulse
- High fill factor
- High photon detection efficiency
- Wide operating voltage range
- Short recovery time
- High count rate

Applications

- Scintillation measurement
- Low-light-level detection
- Scattered light measurement

Related product (sold separately)

- MPPC module C11209-110

Low afterpulse

When an MPPC detects photons, the output may contain spurious signals appearing with a time delay from the light input to the MPPC. These signals are called afterpulses. Compared to our previously marketed products, the S12572 series have drastically reduced afterpulses due to use of improved materials and wafer process technologies. Reducing afterpulses brings various benefits such as a better S/N, a wider operating voltage range, and improved time resolution and photon detection efficiency in high voltage regions.

☑ Pulse waveform comparison

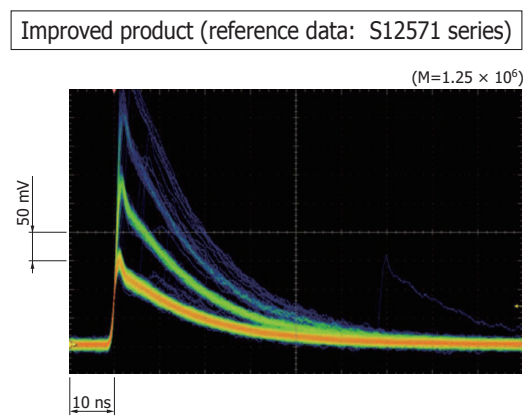
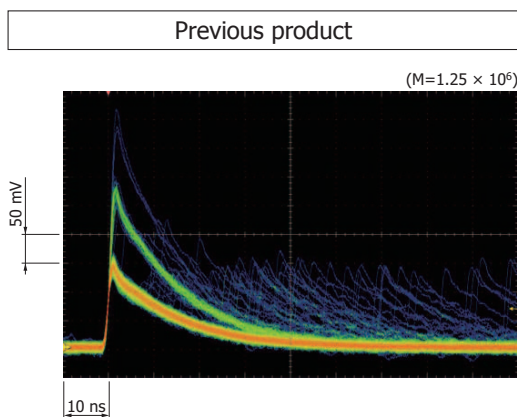

Structure

Parameter	Symbol	S12572				Unit
		-010C	-010P	-015C	-015P	
Effective photosensitive area	-	3 × 3		3 × 3		mm
Pixel pitch	-	10		15		μm
Number of pixels	-	90000		40000		-
Geometrical fill factor	-	33		53		%
Package	-	Ceramic	Surface mount type	Ceramic	Surface mount type	-
Window	-	Epoxy resin		Epoxy resin		-
Window refractive index	-	1.59	1.55	1.59	1.55	-

Absolute maximum ratings (Ta=25 °C)

Parameter	Symbol	S12572				Unit
		-010C	-010P	-015C	-015P	
Operating temperature*1	Topr	-20 to +60		-20 to +60		°C
Storage temperature*1	Tstg	-20 to +80		-20 to +80		°C
Reflow soldering conditions*2	Tsol	-	Peak temperature: 240 °C, twice (see P.6)	-	Peak temperature: 240 °C, twice (see P.6)	-
Soldering conditions	-	350 °C max. once, 3 s max.*3	-	350 °C max. once, 3 s max.*3	-	-

*1: No condensation

When there is a temperature difference between a product and the surrounding area in high humidity environment, dew condensation may occur on the product surface. Dew condensation on the product may cause deterioration in characteristics and reliability.

*2: JEDEC level 5a

*3: At least 1 mm away from lead root

Note: Exceeding the absolute maximum ratings even momentarily may cause a drop in product quality. Always be sure to use the product within the absolute maximum ratings.

Electrical and optical characteristics (Ta=25 °C, unless otherwise noted)

Parameter	Symbol	S12572				Unit
		-010C	-010P	-015C	-015P	
Spectral response range	λ	320 to 900		320 to 900		nm
Peak sensitivity wavelength	λp	470		460		nm
Photon detection efficiency (λ=λp)*4	PDE	10		25		%
Dark count*5	Typ.	1000		1000		kcps
	Max.	2000		2000		
Time resolution (FWHM)*6	-	500		400		ps
Terminal capacitance	Ct	320		320		pF
Gain	M	1.35 × 10 ⁵		2.3 × 10 ⁵		-
Gain temperature coefficient	ΔTM	1.6 × 10 ³		3.5 × 10 ³		/°C
Breakdown voltage	VBR	65 ± 10		65 ± 10		V
Recommended operating voltage	Vop	VBR + 4.5		VBR + 4.0		V
Temperature coefficient of recommended operating voltage	ΔTVop	60		60		mV/°C

*4: Photon detection efficiency does not include crosstalk or afterpulses.

*5: Threshold=0.5 p.e.

*6: Single photon level

Note: The above characteristics were measured at the operating voltage that yields the gain listed in this catalog.

(Refer to the data attached to each product.)

The last letter of each type number indicates the package type (C: ceramic, P: surface mount type).

Photon detection efficiency vs. wavelength

S12572-010C/P

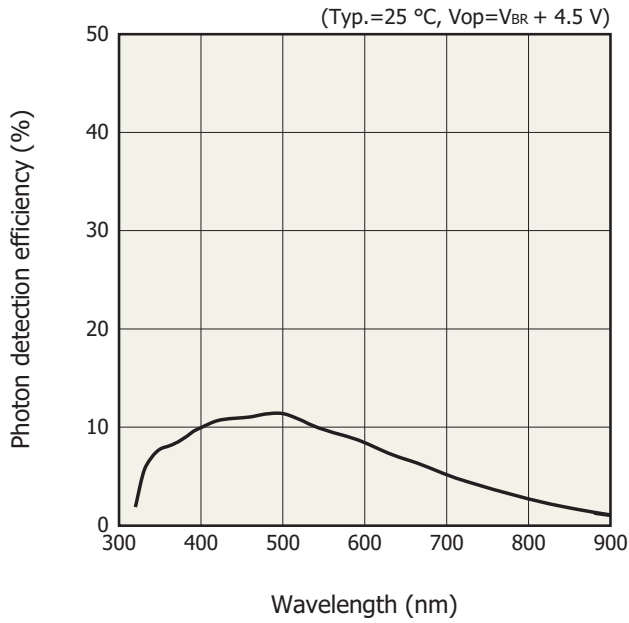

KAPDB0224EA

S12572-015C/P

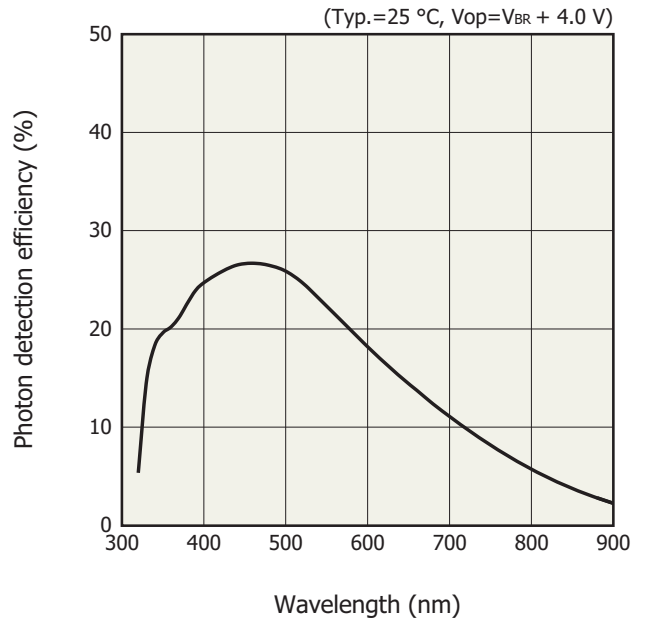

KAPDB0225EA

Photon detection efficiency does not include crosstalk or afterpulses.

Gain vs. overvoltage

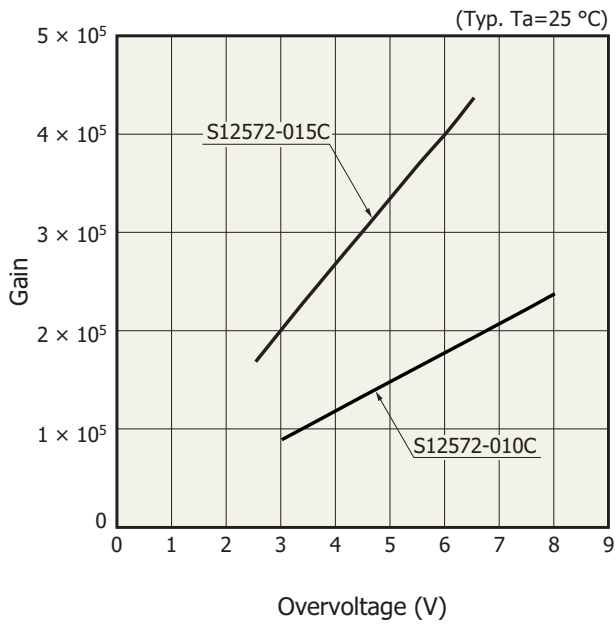

KAPDB0253EA

Photon detection efficiency vs. overvoltage

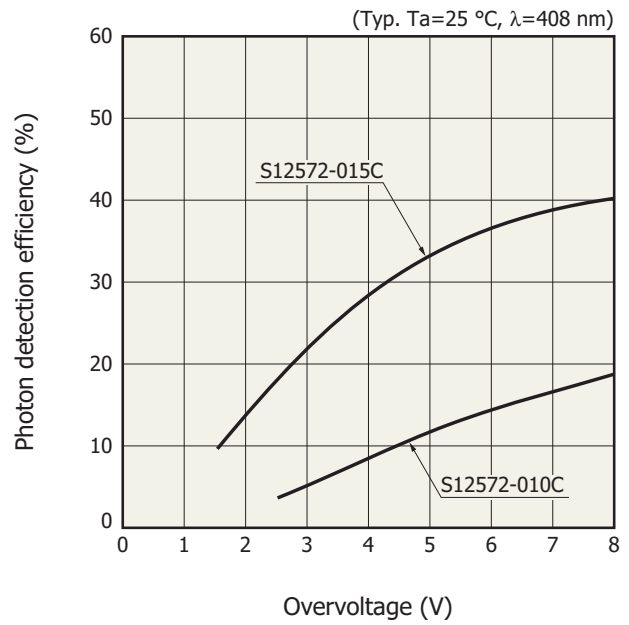

KAPDB0254EB

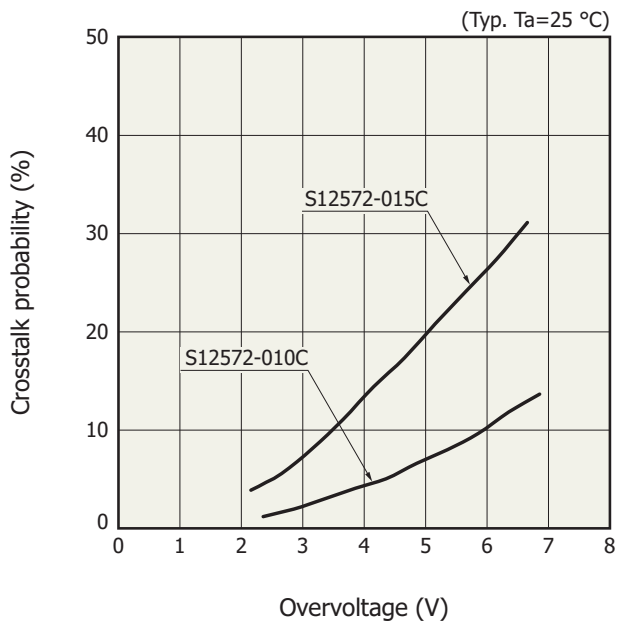
Crosstalk probability vs. overvoltage

KAPDB0255EB

Because the high-speed, wide dynamic range MPPC has a small pixel capacitance, the gain is smaller than the MPPC for general measurement. The gain and photon detection efficiency are increased by applying the higher operating voltage. Please use it with the appropriate operating voltage because the crosstalk increases at the same time.

Dimensional outlines (unit: mm)

S12572-010/-015C

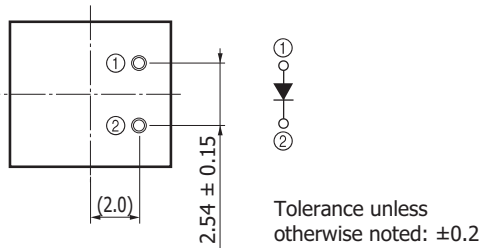
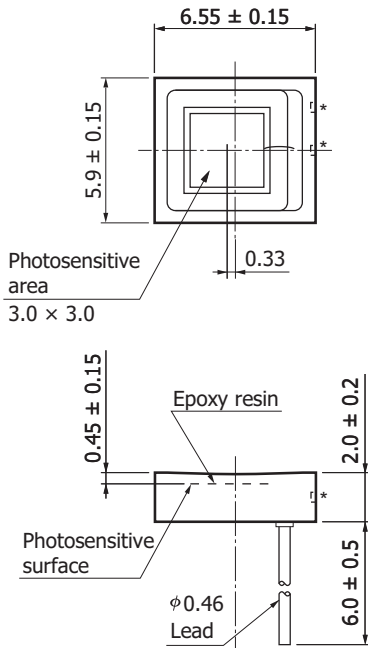

* Metal electrodes connecting to the internal electrodes are exposed on the sides of the ceramic package. To avoid short circuits, never allow other conductors to come in contact with these metal electrodes.

KAPDA0143EA

S12572-010/-015P

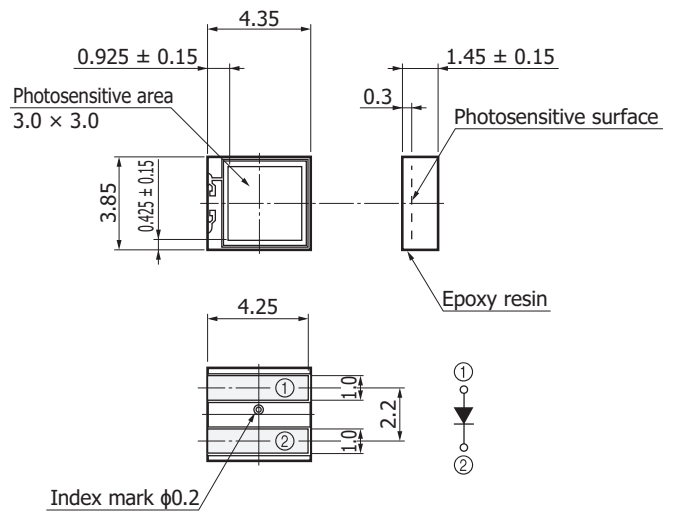

Tolerance unless otherwise noted: ±0.1

KAPDA0144EA

Connection example

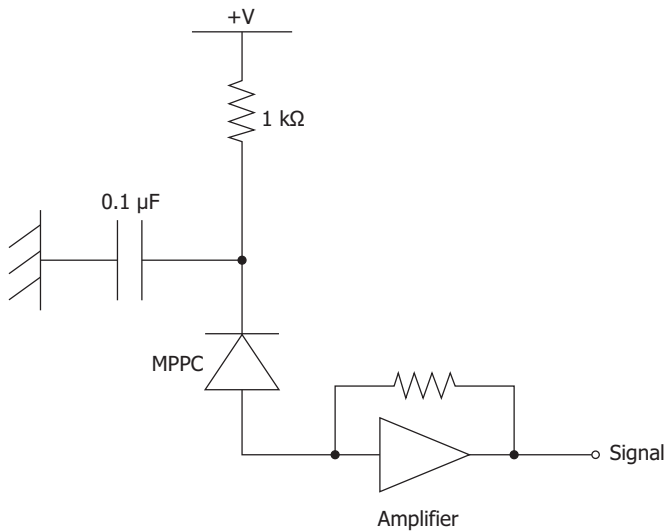

KAPDC0024EB

Measured example of temperature profile with our hot-air reflow oven for product testing

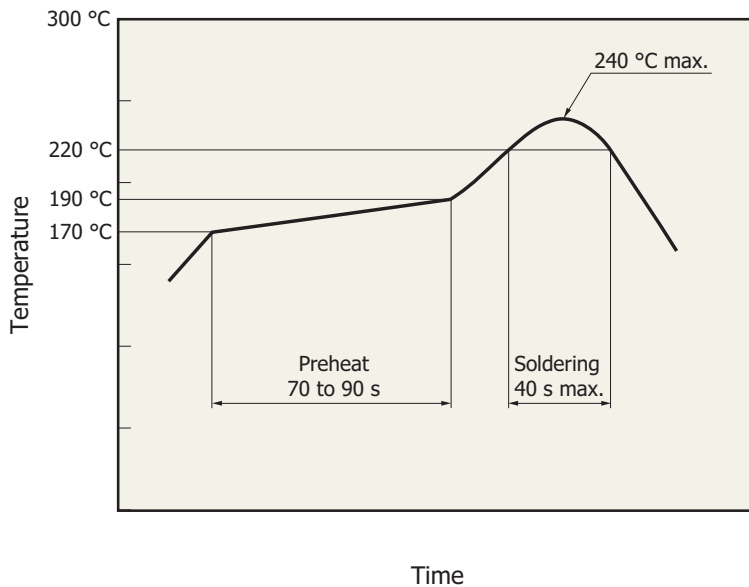

KPICB0171EA

- This surface mount type product supports lead-free soldering. After unpacking, store it in an environment at a temperature of 25°C or less and a humidity of 60% or less, and perform soldering within 24 hours.
- The effect that the product receives during reflow soldering varies depending on the circuit board and reflow oven that are used. Before actual reflow soldering, check for any problems by testing out the reflow soldering methods in advance.

Precautions

- If necessary, incorporate appropriate protective circuits in power supplies, devices, and measuring instruments to prevent overvoltage and overcurrent.

Related information

www.hamamatsu.com/sp/ssd/doc_en.html

■ Precautions

- Disclaimer
- Metal, ceramic, plastic package products
- Surface mount type products

MPPC is a registered trademark of Hamamatsu Photonics K.K.

Information described in this material is current as of December, 2015.

Product specifications are subject to change without prior notice due to improvements or other reasons. This document has been carefully prepared and the information contained is believed to be accurate. In rare cases, however, there may be inaccuracies such as text errors. Before using these products, always contact us for the delivery specification sheet to check the latest specifications.

The product warranty is valid for one year after delivery and is limited to product repair or replacement for defects discovered and reported to us within that one year period. However, even if within the warranty period we accept absolutely no liability for any loss caused by natural disasters or improper product use. Copying or reprinting the contents described in this material in whole or in part is prohibited without our prior permission.

HAMAMATSU

www.hamamatsu.com

HAMAMATSU PHOTONICS K.K., Solid State Division

1126-1 Ichino-cho, Higashi-ku, Hamamatsu City, 435-8558 Japan, Telephone: (81) 53-434-3311, Fax: (81) 53-434-5184

U.S.A.: Hamamatsu Corporation: 360 Foothill Road, Bridgewater, N.J. 08807, U.S.A., Telephone: (1) 908-231-0960, Fax: (1) 908-231-1218

Germany: Hamamatsu Photonics Deutschland GmbH: Arzbergerstr. 10, D-82211 Herrsching am Ammersee, Germany, Telephone: (49) 8152-375-0, Fax: (49) 8152-265-8

France: Hamamatsu Photonics France S.A.R.L.: 19, Rue du Saule Trapu, Parc du Moulin de Massy, 91882 Massy Cedex, France, Telephone: 33-(1) 69 53 71 00, Fax: 33-(1) 69 53 71 10

United Kingdom: Hamamatsu Photonics UK Limited: 2 Howard Court, 10 Tewin Road, Welwyn Garden City, Hertfordshire AL7 1BW, United Kingdom, Telephone: (44) 1707-294888, Fax: (44) 1707-325777

North Europe: Hamamatsu Photonics Norden AB: Torshamnsgatan 35 16440 Kista, Sweden, Telephone: (46) 8-509-031-00, Fax: (46) 8-509-031-01

Italy: Hamamatsu Photonics Italia S.r.l.: Strada della Moia, 1 int. 6, 20020 Arese (Milano), Italy, Telephone: (39) 02-93581733, Fax: (39) 02-93581741

China: Hamamatsu Photonics (China) Co., Ltd.: B1201, Jiaming Center, No.27 Dongsanhuan Beilu, Chaoyang District, Beijing 100020, China, Telephone: (86) 10-6586-6006, Fax: (86) 10-6586-2866