

S10227-10

Small, resin-sealed CMOS image sensor

The S10227-10 is a resin-sealed CMOS linear image sensor to offer compact size and high cost-performance compared to our previous product (S9227 series).

Features

- **Compact and high cost-performance**
Surface mount type package: 4.4 × 9.1 × 1.6^t mm
- **Pixel pitch: 12.5 μm**
Pixel height: 250 μm
- **512 pixels**
- **Single 5 V power supply operation**
- **Video data rate: 5 MHz max.**
- **Simultaneous charge integration**
- **Shutter function**
- **High sensitivity, low dark current, low noise**
- **Built-in timing generator allows operation with only Start and Clock pulse inputs.**
- **Spectral response range: 400 to 1000 nm**

Applications

- **Barcode readers**
- **Displacement meters**
- **Refractometers**
- **Interferometers**
- **Miniature spectrometers**

Structure

Parameter	Specification	Unit
Number of pixels	512	-
Pixel pitch	12.5	μm
Pixel height	250	μm
Photosensitive area length	6.4	mm
Package	Glass epoxy	-
Seal material	Silicone resin	-

Absolute maximum ratings

Parameter	Symbol	Condition	Value	Unit
Supply voltage	V _{dd}	T _a =25 °C	-0.3 to +6	V
Clock pulse voltage	V(CLK)	T _a =25 °C	-0.3 to +6	V
Start pulse voltage	V(ST)	T _a =25 °C	-0.3 to +6	V
Operating temperature* ¹	T _{opr}		-25 to +85	°C
Storage temperature* ¹	T _{stg}		-25 to +85	°C
Reflow soldering conditions* ²	T _{sol}		Peak temperature 260°C, 3 times (See P.6)	-

*1: No dew condensation

When there is a temperature difference between a product and the surrounding area in high humidity environment, dew condensation may occur on the product surface. Dew condensation on the product may cause deterioration in characteristics and reliability.

*2: JEDEC level 2a

Note: Exceeding the absolute maximum ratings even momentarily may cause a drop in product quality. Always be sure to use the product within the absolute maximum ratings.

Recommended terminal voltage

Parameter	Symbol	Min.	Typ.	Max.	Unit
Supply voltage	Vdd	4.75	5	5.25	V
Clock pulse voltage	High level	Vdd - 0.25	Vdd	Vdd + 0.25	V
	Low level	-	0	-	V
Start pulse voltage	High level	Vdd - 0.25	Vdd	Vdd + 0.25	V
	Low level	-	0	-	V

Electrical characteristics [Ta=25 °C, Vdd=5 V, V(CLK)=V(ST)=5 V]

Parameter	Symbol	Min.	Typ.	Max.	Unit
Clock pulse frequency	f(CLK)	50 k	-	5 M	Hz
Video data rate	VR	-	f(CLK)	-	Hz
Current consumption	I	20	26	32	mA
Conversion efficiency	CE	-	1.6	-	μV/e ⁻

Electrical and optical characteristics [Ta=25 °C, Vdd=5 V, V(CLK)=V(ST)=5 V, f(CLK)=5 MHz]

Parameter	Symbol	Min.	Typ.	Max.	Unit
Spectral response range	λ	400 to 1000			nm
Peak sensitivity wavelength	λp	-	700	-	nm
Dark output voltage*3	Vd	-	1	10	mV
Saturation output voltage*4	Vsat	4	4.3	-	V
Readout noise	Nr	-	0.45	1	mV rms
Output offset voltage	Vo	0.4	0.6	0.9	V
Photoresponse nonuniformity*5 *6	PRNU	-	-	±8.5	%

*3: Integration time=10 ms

*4: Voltage difference from Vo

*5: Photoresponse nonuniformity (PRNU) is the output nonuniformity that occurs when the entire photosensitive area is uniformly illuminated by light which is 50% of the saturation exposure level. PRNU is measured using 510 pixels excluding the pixels at both ends, and is defined as follows:

$$PRNU = \frac{\Delta X}{X} \times 100 (\%)$$

X: average output of 510 pixels excluding the pixels at both ends, ΔX: difference between X and maximum or minimum output

*6: Measured with a tungsten lamp of 2856 K

Spectral response (typical example)

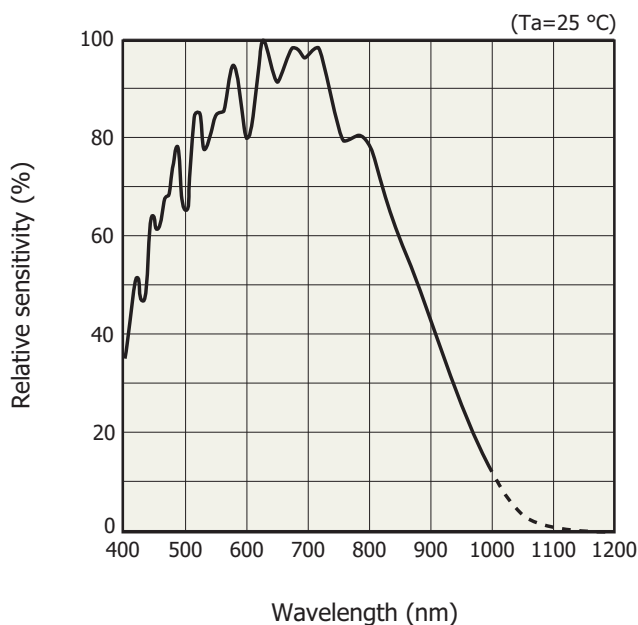

KMPDB0258ED

Block diagram

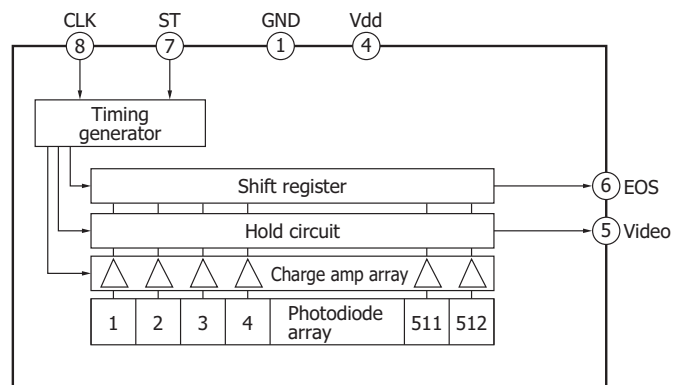

KMPDB0167EC

Timing chart

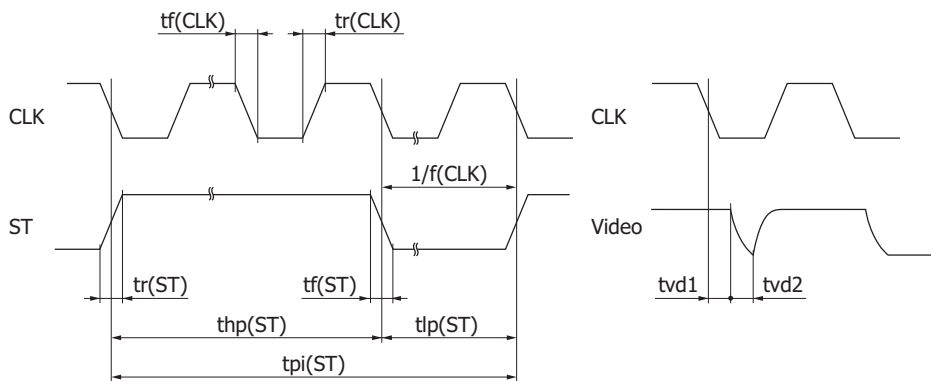
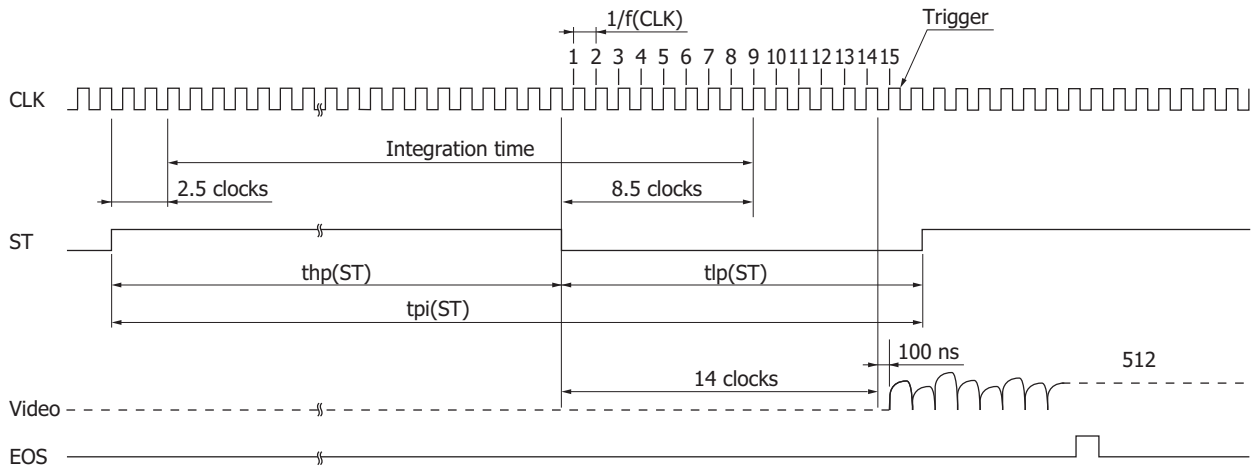

KMPDC0166EF

Parameter	Symbol	Min.	Typ.	Max.	Unit
Start pulse interval	$t_{pi}(\text{ST})$	$530/f(\text{CLK})$	-	1100 m	s
Start pulse high period	$t_{hp}(\text{ST})$	$8/f(\text{CLK})$	-	1000 m	s
Start pulse low period	$t_{lp}(\text{ST})$	$15/f(\text{CLK})$	-	100 m	s
Start pulse rise and fall times	$t_r(\text{ST}), t_f(\text{ST})$	0	20	30	ns
Clock pulse duty	-	45	50	55	%
Clock pulse rise and fall times	$t_r(\text{CLK}), t_f(\text{CLK})$	0	20	30	ns
Video delay time 1	t_{vd1}	32	40	48	ns
Video delay time 2	t_{vd2}	40	50	60	ns

Note: Dark output increases if the start pulse period or the start pulse high period is lengthened.
 The internal timing circuit starts operating at the rise of CLK pulse immediately after ST pulse sets to low.
 The integration time equals the high period of ST pulse plus 6 CLK cycles.
 The output from 1st channel appears 14 clocks plus 100 ns after the falling edge of ST pulse.
 The EOS pulse is output 39 ns after the falling edge of CLK pulse.
 The output voltage after reading the last pixel (512 ch) is indefinite.

Start pulse setting example (for setting the start pulse period to a minimum and the integration time to a maximum)
 Start pulse high period= $515/f(\text{CLK})$, Start pulse low period= $15/f(\text{CLK})$

Dimensional outline (unit: mm)

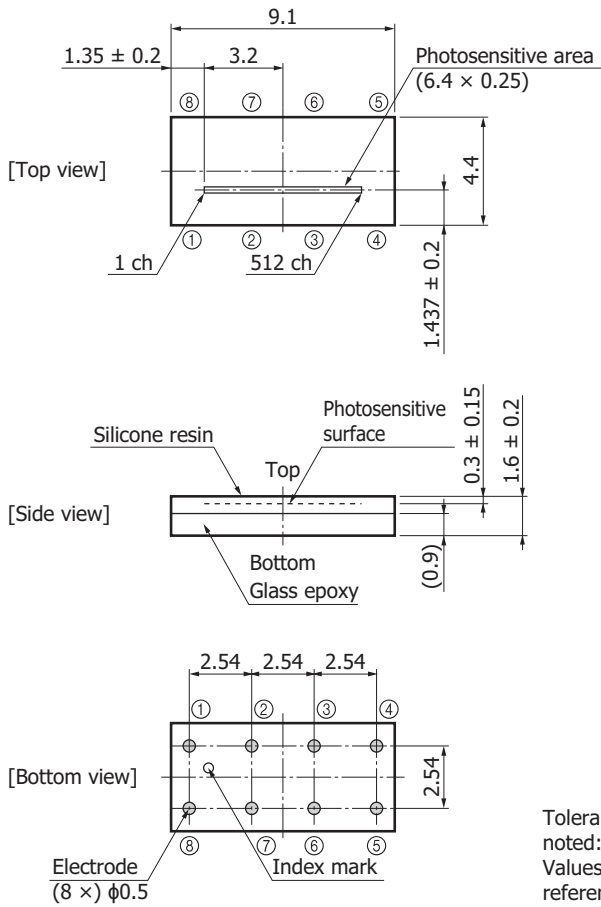

KMPDA0316EB

Pin connections

Pin no.	Symbol	I/O	Discription
1	GND	-	Ground
2	NC	-	No connection
3	NC	-	No connection
4	Vdd	I	Power supply voltage
5	Video	O	Video signal output
6	EOS	O	End of scan
7	ST	I	Start pulse
8	CLK	I	Clock pulse

Recommended land pattern (unit: mm)

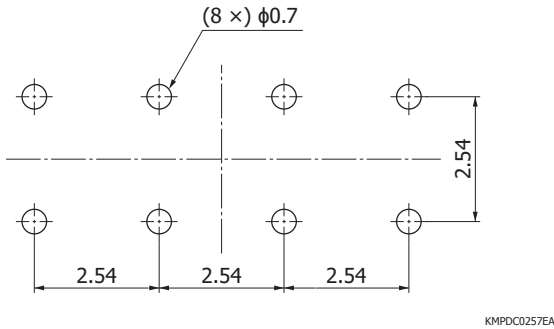

Appearance inspection standards

Parameter	Test criterion	Inspection method
Foreign matter on photosensitive area	10 μm max.	Automated camera

Standard packing specifications

- Reel (conforms to JEITA ET-7200)

Dimensions	Hub diameter	Tape width	Material	Electrostatic characteristic
330 mm	100 mm	16 mm	PPE	Conductive

- Embossed tape (unit: mm, material: polycarbonate resin, conductive)

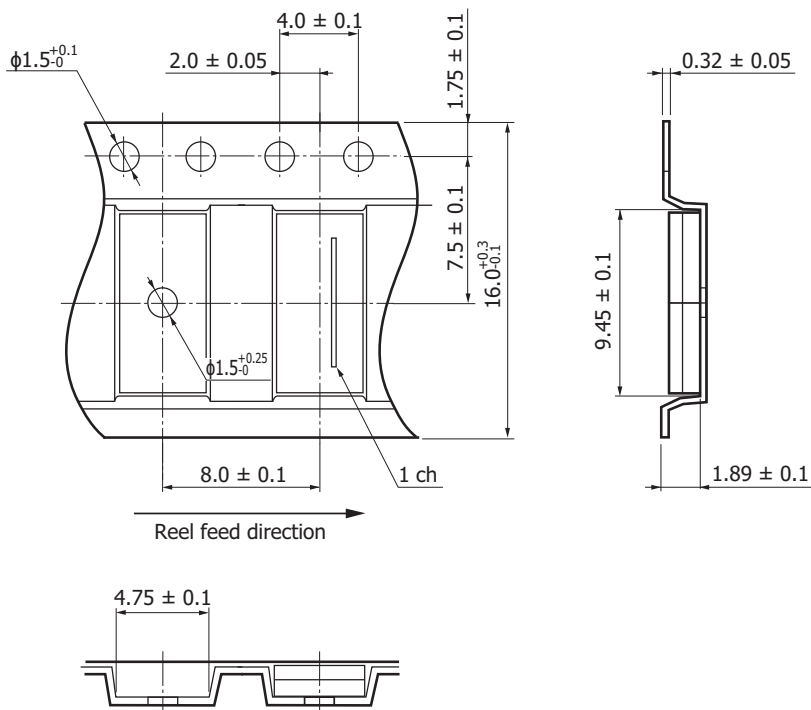

KMPDC0450EA

- Packing quantity
2000 pcs/reel
- Packing type
Reel and desiccant in moisture-proof packing (vacuum-sealed)

Recommended temperature profile for reflow soldering (typical example)

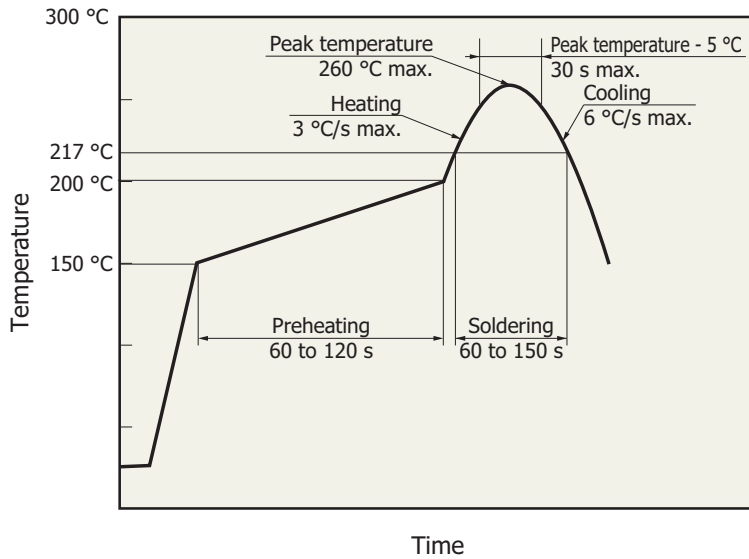

KMPD80405EB

- This product supports lead-free soldering. After unpacking, store it in an environment at a temperature of 30 °C or less and a humidity of 60% or less, and perform soldering within 4 weeks.
- The effect that the product receives during reflow soldering varies depending on the circuit board and reflow oven that are used. Before actual reflow soldering, check for any problems by testing out the reflow soldering methods in advance.
- When three or more months have passed or if the packing bag has not been stored in an environment described above, perform baking. For the baking method, see the related information "Resin sealed type CMOS linear image sensor / Precautions."

Precautions

(1) Electrostatic countermeasures

- This device has a built-in protection circuit as a safeguard against static electrical charges. However, to prevent destroying the device with electrostatic charges, take countermeasures such as grounding yourself, the workbench and tools.
- Protect this device from surge voltages which might be caused by peripheral equipment.

(2) Package handling

- The photosensitive area of this device is sealed and protected by transparent resin. When compared to a glass faceplate, the surface of transparent resin may be less uniform and is more likely to be scratched. Be very careful when handling this device and also when designing the optical systems.
- Dust or grime on the light input window might cause nonuniform sensitivity. To remove dust or grime, blow it off with compressed air.

(3) Surface protective tape

- Protective tape is affixed to the surface of this product to protect the photosensitive area. After assembling the product, remove the tape before use.

(4) Operating and storage environments

- Handle the device within the temperature range specified in the absolute maximum ratings. Operating or storing the device at an excessively high temperature and humidity may cause variations in performance characteristics and must be avoided.

(5) UV exposure

- This product is not designed to prevent deterioration of characteristics caused by UV exposure, so do not expose it to UV light.

Related information

www.hamamatsu.com/sp/ssd/doc_en.html

■ Precautions

- Disclaimer
- Image sensors
- Resin-sealed CMOS linear image sensors

Information described in this material is current as of June 2016.

Product specifications are subject to change without prior notice due to improvements or other reasons. This document has been carefully prepared and the information contained is believed to be accurate. In rare cases, however, there may be inaccuracies such as text errors. Before using these products, always contact us for the delivery specification sheet to check the latest specifications.

The product warranty is valid for one year after delivery and is limited to product repair or replacement for defects discovered and reported to us within that one year period. However, even if within the warranty period we accept absolutely no liability for any loss caused by natural disasters or improper product use. Copying or reprinting the contents described in this material in whole or in part is prohibited without our prior permission.

HAMAMATSU

www.hamamatsu.com

HAMAMATSU PHOTONICS K.K., Solid State Division

1126-1 Ichino-cho, Higashi-ku, Hamamatsu City, 435-8558 Japan, Telephone: (81) 53-434-3311, Fax: (81) 53-434-5184

U.S.A.: Hamamatsu Corporation: 360 Foothill Road, Bridgewater, N.J. 08807, U.S.A., Telephone: (1) 908-231-0960, Fax: (1) 908-231-1218

Germany: Hamamatsu Photonics Deutschland GmbH: Arzbergerstr. 10, D-82211 Herrsching am Ammersee, Germany, Telephone: (49) 8152-375-0, Fax: (49) 8152-265-8

France: Hamamatsu Photonics France S.A.R.L.: 19, Rue du Saule Trapu, Parc du Moulin de Massy, 91882 Massy Cedex, France, Telephone: 33-(1) 69 53 71 00, Fax: 33-(1) 69 53 71 10

United Kingdom: Hamamatsu Photonics UK Limited: 2 Howard Court, 10 Tewin Road, Welwyn Garden City, Hertfordshire AL7 1BW, United Kingdom, Telephone: (44) 1707-294888, Fax: (44) 1707-325777

North Europe: Hamamatsu Photonics Norden AB: Torshamnsgatan 35 16440 Kista, Sweden, Telephone: (46) 8-509-031-00, Fax: (46) 8-509-031-01

Italy: Hamamatsu Photonics Italia S.r.l.: Strada della Moia, 1 int. 6, 20020 Arese (Milano), Italy, Telephone: (39) 02-93581733, Fax: (39) 02-93581741

China: Hamamatsu Photonics (China) Co., Ltd.: B1201, Jiaming Center, No.27 Dongsanhuan Beilu, Chaoyang District, Beijing 100020, China, Telephone: (86) 10-6586-6006, Fax: (86) 10-6586-2866