

InGaAs linear image sensors

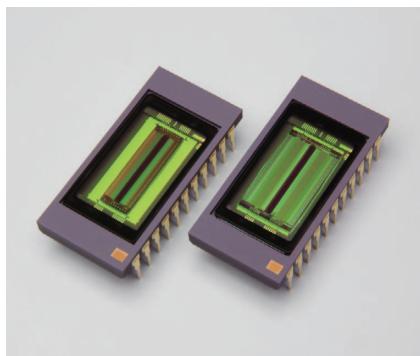

G11135-256DD, G11135-512DE

Single video line (256/512 pixels) near infrared image sensor (0.95 to 1.7 μm)

The G11135 series InGaAs linear image sensors designed for foreign object inspection equipment. These linear image sensors consist of an InGaAs photodiode array and CMOS chip that contains a charge amplifier array, an offset compensation circuit, a shift register, and a timing generator. The InGaAs photodiode array and the CMOS chip are electrically connected by indium bumps.

The charge amplifier array is made up of CMOS transistors connected to each pixel of the InGaAs photodiode array.

Signals from each pixel are read out in charge integration mode to achieve high sensitivity and stable operation in the near infrared spectral range.

The signal processing circuit on the CMOS chip offers two levels of conversion efficiency (CE) that can be selected by the external voltage to meet the application.

Features

- Single video line (256/512 pixels)
- High-speed data rate: 5 MHz max.
- Choice of two conversion efficiency levels
- Pixel size: G11135-256DD (50 × 50 μm)
G11135-512DE (25 × 25 μm)
- Built-in temperature sensor
- Small variations in dark output between pixels
- Room temperature operation

Applications

- Foreign object screening
- Agricultural product inspection

Related products

- Driver circuit for InGaAs liner image sensor C11514

General ratings

Parameter	G11135-256DD	G11135-512DE	Unit
Cooling	Non-cooled		-
Number of total pixels	256	512	pixels
Number of effective pixels	256	512	pixels
Image size	12.8 × 0.05	12.8 × 0.025	mm
Pixel size	50 × 50	25 × 25	μm (H) × μm (V)
Pixel pitch	50	25	μm
Package	22-pin ceramic (refer to the dimensional outline)		-
Window material	Borosilicate glass with anti-reflective coating		-

Cross sectional image

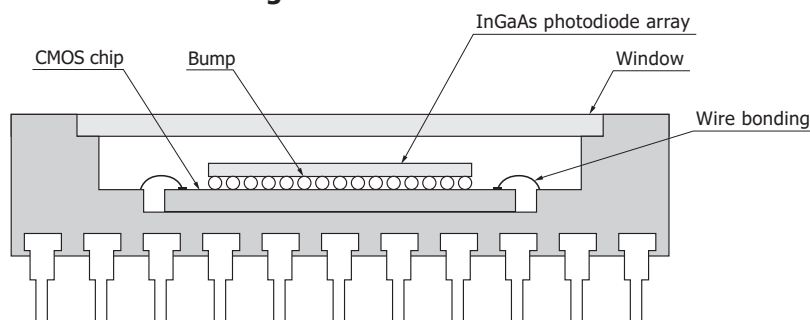

KMIRC0053EA

Block diagram (G11135-512DE)

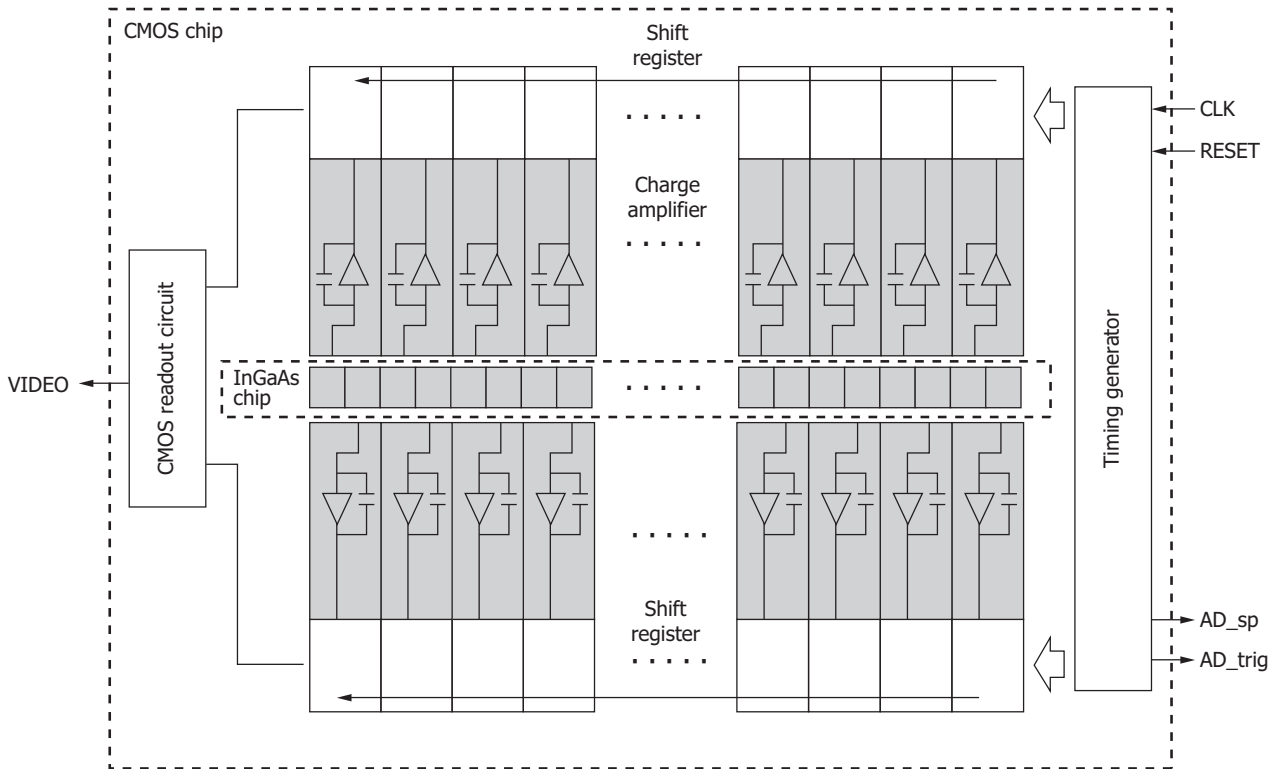

KMIRC0048EA

Absolute maximum ratings

Parameter	Symbol	Condition	Value	Unit
Supply voltage	Vdd, INP, Fvref, Vinp, PDN	Ta=25 °C	-0.3 to +6.0	V
Clock voltage	Vφ	Ta=25 °C	-0.3 to +6.0	V
Reset pulse voltage	V(RESET)	Ta=25 °C	-0.3 to +6.0	V
Gain selection terminal voltage	Vcfssel	Ta=25 °C	-0.3 to +6.0	V
Operating temperature	Topr		-10 to +60	°C
Storage temperature	Tstg		-20 to +70	°C
Soldering conditions	-		260 °C or less, within 5 s	-
Thermistor power dissipation	Pd_th	Ta=25 °C	400 max.	mW

Note: This product must be used within the range of the absolute maximum ratings. Product quality may suffer if any item of the absolute maximum ratings is exceeded even momentarily.

Recommended terminal voltage

Parameter	Symbol	Min.	Typ.	Max.	Unit
Supply voltage	Vdd	4.7	5.0	5.3	V
Differential reference voltage	Fvref	1.1	1.2	1.3	V
Video line reset voltage	Vinp	3.9	4.0	4.1	V
Input stage amplifier reference voltage	INP	3.9	4.0	4.1	V
Pixel voltage	PDN	3.9	4.0	4.1	V
Clock pulse voltage	High	4.7	5	5.3	V
	Low	-	0	0.4	
Reset pulse voltage	High	4.7	5	5.3	V
	Low	-	0	0.3	

Electrical and optical characteristics (Ta=25 °C, Vdd=5 V, INP, Vinp, PDN=4 V, Fvref=1.2 V, f=5 MHz)

Parameter	Symbol	Condition	Min.	Typ.	Max.	Unit
Spectral response range	λ			0.95 to 1.7	-	μm
Peak sensitivity wavelength	λ_p		1.45	1.55	1.65	μm
Photo sensitivity	S	$\lambda=\lambda_p$	0.7	0.82	-	A/W
Conversion efficiency*1	CE	High gain	-	930	-	nV/e ⁻
		Low gain		160		
Saturation charge*2	Qsat		-	2.8	-	Me ⁻
Saturation voltage*2	Vsat		2.3	2.6	-	V
Photoresponse nonuniformity*3	PRNU		-	± 5	± 10	%
Average dark output*4	Vdmean		1.05	1.25	1.45	V
Dark output nonuniformity*4	DSNU		-	± 3	± 10	mV
Readout noise*4	N		-	1	2	mV rms
Dynamic range	D		1200	2600	-	-
Defective pixels*5	-		-	-	1	%

*1: Cf_select=0 V (high gain), 5 V (low gain)

*2: High gain, integration time 500 μs

*3: High gain, 50% of saturation, after dark output subtraction, excluding first and last pixels, integration time 200 μs

*4: High gain, integration time 200 μs

*5: Pixels with photoresponse nonuniformity, readout noise, or dark output nonuniformity higher than the maximum value

Electrical characteristics (Ta=25 °C)

Parameter	Symbol	Min.	Typ.	Max.	Unit
Supply current	256 ch	-	50	75	mA
	512 ch		75	100	
Differential reference current	Ifvref	-	-	1	mA
Video line reset voltage	Ivinp	-	-	1	mA
Input stage amplifier reference current	I(INP)	-	-	1	mA
Pixel voltage	I(PDN)	-	-	1	mA
Output voltage	High	-	3.85	-	V
	Low		1.25	-	
Clock frequency	f	0.1	-	5	MHz
Output impedance	Zo	-	5	-	k Ω
Data rate	DR	0.1	f	5	MHz
A/D trigger, A/D start pulse voltage	High	-	Vdd	-	V
	Low		GND	-	
Thermistor resistance	Rth	-	10	-	k Ω
Thermistor B constant*6	B	-	3950	-	K

*6: T1=25 °C, T2=50 °C

Equivalent circuit

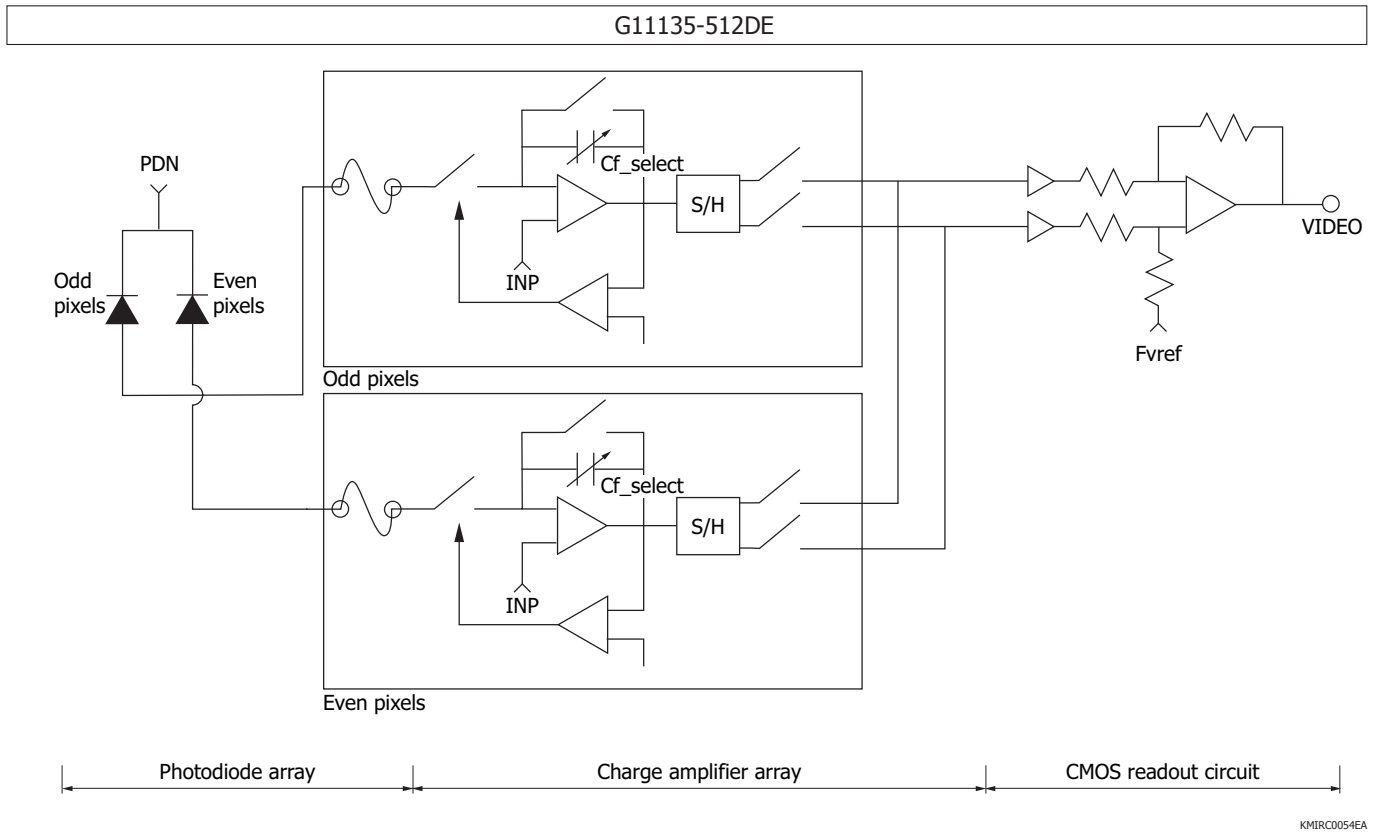
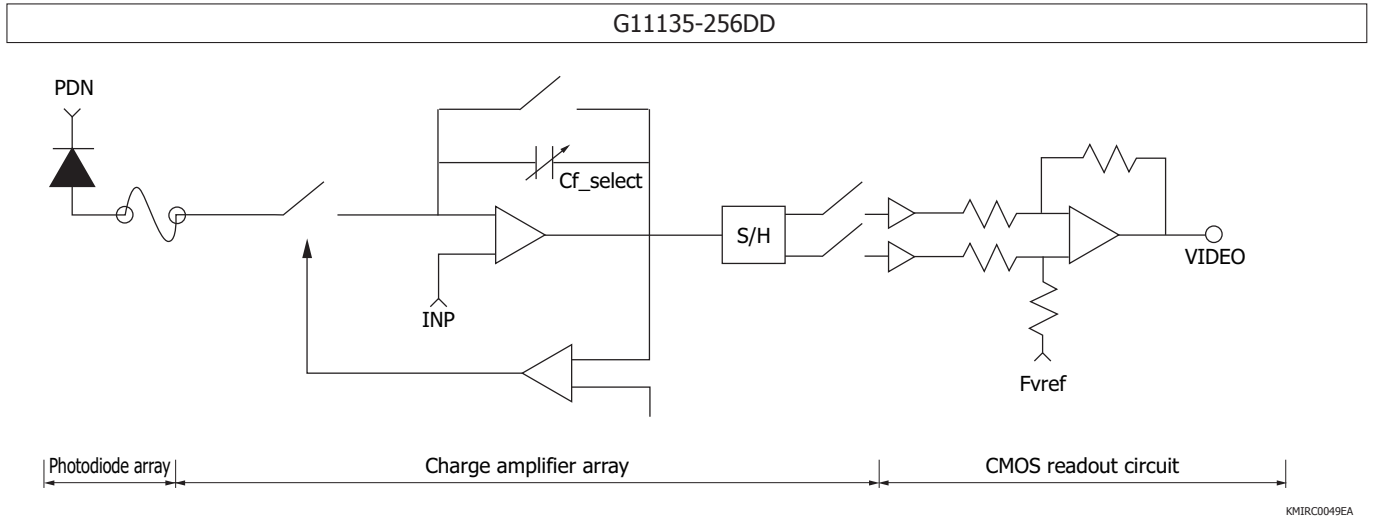

Connection example

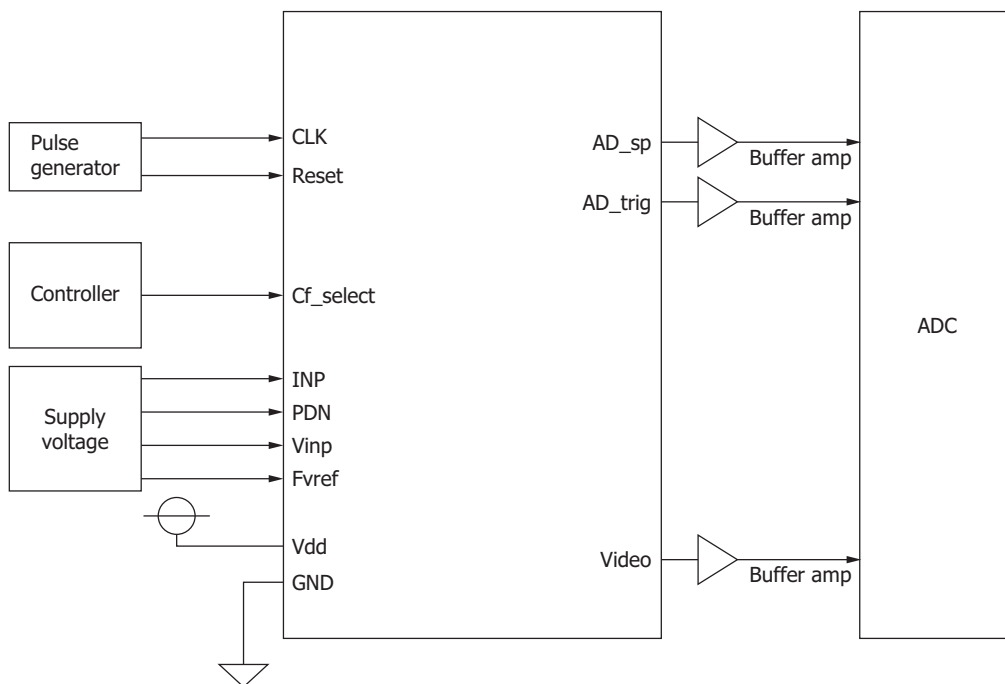

KMIRC0051EA

Timing chart (G11135-512DE)

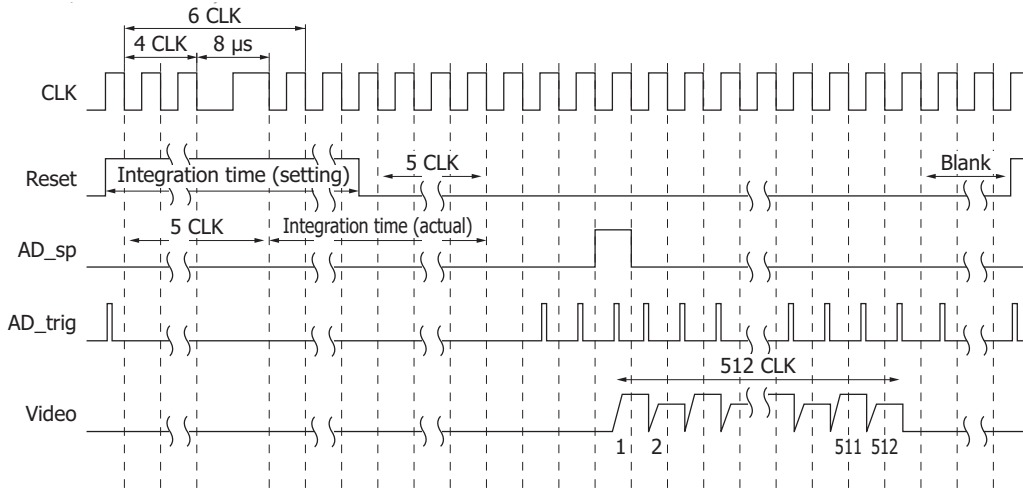

Integration time (actual) = Integration time (setting) - 8 μs + 1 CLK

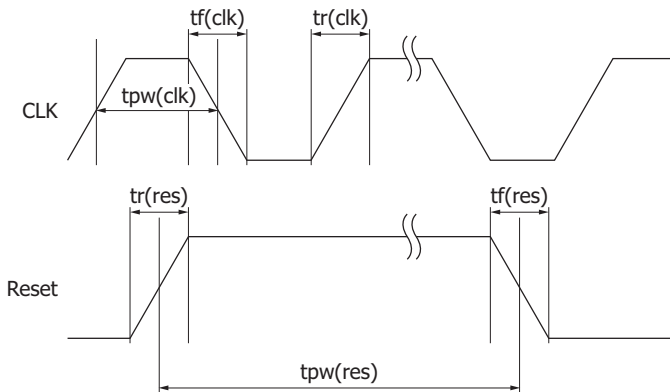

KMIRC0050EC

Parameter	Symbol	Min.	Typ.	Max.	Unit
Clock pulse frequency	f	0.1	-	5	MHz
Clock pulse width	tpw(clk)	60	100	-	ns
Clock pulse rise/fall times	tr(clk), tf(clk)	0	20	30	ns
Reset pulse width	tpw(res)	*7	-	_*8	clock
		Number of channels + 12	-	-	
Reset pulse rise/fall times	tr(res), tf(res)	0	20	30	ns

*7: (5 CLK + 8 μs) or (18 μs - 1 CLK), whichever is longer.

*8: 1.008 ms - 1 CLK

Spectral response

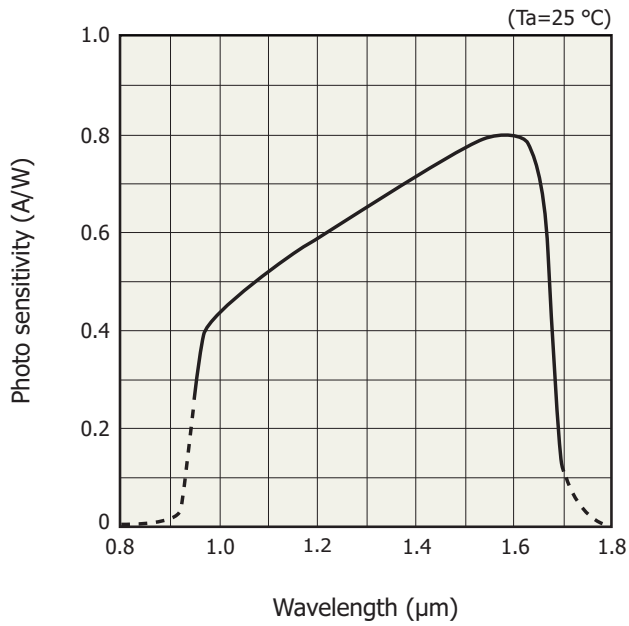

KMIRB0051EB

Temperature characteristics of thermistor

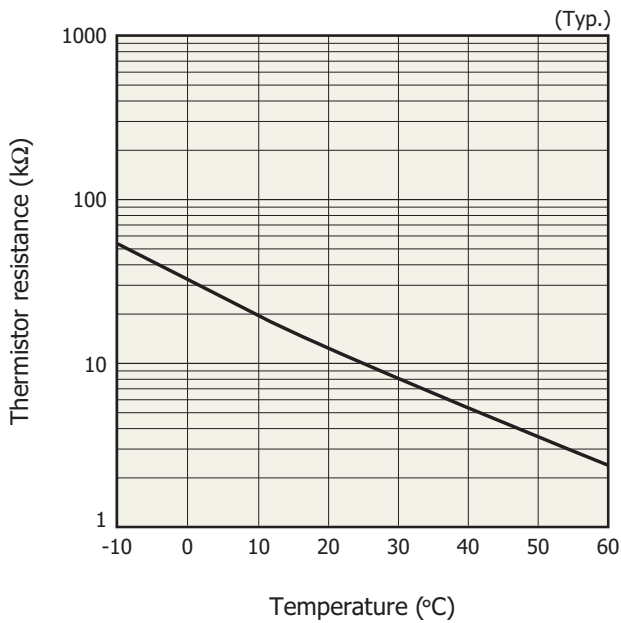

KMIRB0059EA

(Typ.)

Temperature (°C)	Thermistor resistance (kΩ)
-10	53.0
-5	41.2
0	32.1
5	25.1
10	19.8
15	15.7
20	12.5
25	10.0
30	8.06
35	6.53
40	5.32
45	4.36
50	3.59
55	2.97
60	2.47

Pin connections

Terminal name	Input/Output	Function and recommended connection	Remark
PDN	Input	Cathode bias terminal for InGaAs photodiode	4.0 V
AD_sp	Output	Digital start signal for A/D conversion	0 to 5 V
Cf_select	Input*9	Signal for selecting feedback capacitance (integration capacitance) on CMOS chip	0 V or 5 V
Thermistor	Output	Thermistor for monitoring temperature inside the package	-
AD_trig	Output	Sampling synchronous signal for A/D conversion	0 to 5 V
RESET	Input	Reset pulse for initializing the feedback capacitance in the charge amplifier formed in the CMOS chip. Integration time is determined by the high period of this pulse.	0 to 5 V
CLK	Input	Clock pulse for operating the CMOS shift register	0 to 5 V
INP	Input	Input stage amplifier reference voltage. Supply voltage for operating the signal processing circuit in the CMOS chip.	4.0 V
Vinp	Input	Video line reset voltage. Supply voltage for operating the signal processing circuit in the CMOS chip.	4.0 V
Fvref	Input	Differential amplifier reference voltage. Supply voltage for operating the signal processing circuit in the CMOS chip.	1.2 V
VIDEO	Output	Differential amplifier output. Analog video signal.	1.25 to 3.85 V
Vdd	Input	Supply voltage for operating the signal processing circuit in the CMOS chip (+5 V)	5 V
GND	Input	Ground for the signal processing circuit in the CMOS chip (0 V)	0 V

*9: Conversion efficiency is determined by supply voltage to the Cf_select terminals as shown below.

Conversion efficiency	Cf_select
160 nV/e ⁻	High
930 nV/e ⁻	Low

Low: 0 V (GND), High: 5 V (Vdd)

Dimensional outline (unit: mm)

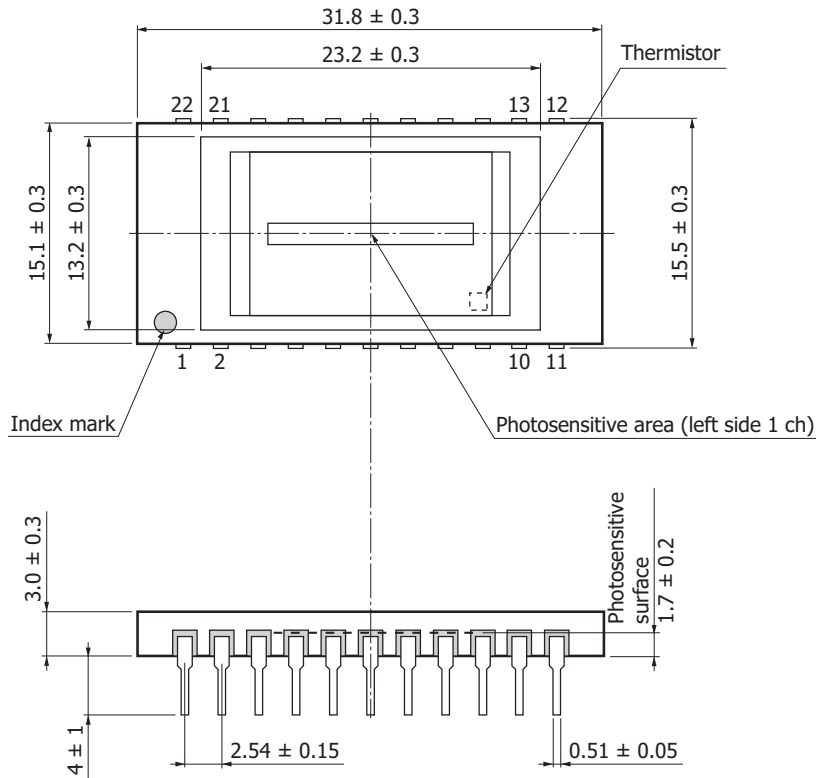

Pin no.	Function	Pin no.	Function
1	NC	12	Video
2	NC	13	V _{inp}
3	NC	14	CLK
4	NC	15	PDN
5	GND	16	INP
6	Cf_select	17	GND
7	Thermistor	18	V _{dd}
8	Thermistor	19	NC
9	NC	20	AD_trig
10	Fvref	21	Reset
11	NC	22	AD_sp

Position accuracy of photosensitive area center: $-0.3 \leq X \leq +0.3$
 $-0.3 \leq Y \leq +0.3$
 Position accuracy of photosensitive area inclination: $-5^\circ \leq \theta \leq +5^\circ$
 Package material: ceramic
 Lead treatment: Ni/Au plating
 Lead material: FeNi alloy
 Window material: borosilicate glass
 Window material thickness: 0.75 ± 0.05 mm
 Reflective index of window material: $n_d=1.47$
 AR coat: coated (1.55 μ m peak)
 Window sealing method: resin bonding

Note: NC should be left open.
 Do not connect it to GND.

KMIRA0022EE

Electrostatic countermeasures

This device has a built-in protection circuit against static electrical charges. However, to prevent destroying the device with electrostatic charges, take countermeasures such as grounding yourself, the workbench and tools to prevent static discharges. Also protect this device from surge voltages which might be caused by peripheral equipment.

Related information

www.hamamatsu.com/sp/ssd/doc_en.html

■ Precautions

- Disclaimer
- Image sensors

Information described in this material is current as of July, 2015.

Product specifications are subject to change without prior notice due to improvements or other reasons. This document has been carefully prepared and the information contained is believed to be accurate. In rare cases, however, there may be inaccuracies such as text errors. Before using these products, always contact us for the delivery specification sheet to check the latest specifications.

The product warranty is valid for one year after delivery and is limited to product repair or replacement for defects discovered and reported to us within that one year period. However, even if within the warranty period we accept absolutely no liability for any loss caused by natural disasters or improper product use. Copying or reprinting the contents described in this material in whole or in part is prohibited without our prior permission.

HAMAMATSU

www.hamamatsu.com

HAMAMATSU PHOTONICS K.K., Solid State Division

1126-1 Ichino-cho, Higashi-ku, Hamamatsu City, 435-8558 Japan, Telephone: (81) 53-434-3311, Fax: (81) 53-434-5184

U.S.A.: Hamamatsu Corporation: 360 Foothill Road, Bridgewater, N.J. 08807, U.S.A., Telephone: (1) 908-231-0960, Fax: (1) 908-231-1218

Germany: Hamamatsu Photonics Deutschland GmbH: Arzbergerstr. 10, D-82211 Herrsching am Ammersee, Germany, Telephone: (49) 8152-375-0, Fax: (49) 8152-265-8

France: Hamamatsu Photonics France S.A.R.L.: 19, Rue du Saule Trapu, Parc du Moulin de Massy, 91882 Massy Cedex, France, Telephone: 33-(1) 69 53 71 00, Fax: 33-(1) 69 53 71 10

United Kingdom: Hamamatsu Photonics UK Limited: 2 Howard Court, 10 Tewin Road, Welwyn Garden City, Hertfordshire AL7 1BW, United Kingdom, Telephone: (44) 1707-294888, Fax: (44) 1707-325777

North Europe: Hamamatsu Photonics Norden AB: Torshamnsgatan 35 16440 Kista, Sweden, Telephone: (46) 8-509-031-00, Fax: (46) 8-509-031-01

Italy: Hamamatsu Photonics Italia S.r.l.: Strada della Moia, 1 int. 6, 20020 Arese (Milano), Italy, Telephone: (39) 02-93581733, Fax: (39) 02-93581741

China: Hamamatsu Photonics (China) Co., Ltd.: B1201, Jiaming Center, No.27 Dongsanhuan Beilu, Chaoyang District, Beijing 100020, China, Telephone: (86) 10-6586-6006, Fax: (86) 10-6586-2866