

# Mini-spectrometer

[ TG series ]

C11482GA



**For near IR, integrating optical system,  
image sensor and circuit**

Hamamatsu TG series mini-spectrometer C11482GA is a polychromator integrated with optical elements and an image sensor. Light to be measured is guided into the entrance port of the C11482GA through an optical fiber and the spectrum measured with the built-in image sensor is output from the USB port to a PC for data acquisition. The C11482GA is a palm-top-size unit and operates on USB bus power. It comes supplied with evaluation software that allows setting measurement conditions, acquiring and saving data, and displaying graphs. Original measurement software can be designed on an end-user's side as DLL's function specification is disclosed.

## Features

- High throughput due to transmission grating made of quartz
- Highly accurate optical characteristics
- No external power supply required (uses USB bus power)
- Compact design for easy assembly
- Wavelength conversion factor\*1 is recorded in internal memory

## Applications

- Water content measurement
- Optical communication component testing
- Film thickness measurement

\*1: A conversion factor for converting the image sensor pixel number into a wavelength is recorded in the module. A calculation factor for converting the A/D converted count into the input light level is not provided.

## Optical characteristics

Parameter	Specification	Unit
Spectral response range	900 to 1700	nm
Spectral resolution (FWHM)*2	7 max.	nm
Wavelength reproducibility*3	-0.2 to +0.2	nm
Wavelength temperature dependence	-0.04 to +0.04	nm/°C
Spectral stray light*2 *4	-33 max.	dB

\*2: Depends on the slit opening. Values were measured with the slit listed in the table "Structure".

\*3: Measured under constant light input conditions

\*4: When monochromatic light of 1300 nm is input, spectral stray light is defined as the ratio of the count measured at the input wavelength, to the count measured in a region of the input wavelength  $\pm 40$  nm.

## Electrical characteristics

Parameter	Specification	Unit
A/D conversion	16	bit
Integration time	6 $\mu$ s to 10 s	-
Interface	USB 2.0	-
Current consumption of USB bus power	350 max.	mA

**Structure**

Parameter	Specification	Unit
Dimensions (W × D × H)	38.5 × 106 × 86	mm
Weight	280	g
Image sensor	InGaAs linear image sensor (G9204-512D)	-
Number of pixels*5	512	pixels
Slit*6 (H × V)	70 × 500	μm
NA*7	0.22	-
Connector for optical fiber	SMA905D	-

\*5: No defective pixel (when inspecting at low gain). Defective pixels are those whose electrical and optical characteristics do not meet our specifications.

\*6: Entrance slit aperture size

\*7: Numeric aperture (solid angle)

**Absolute maximum ratings**

Parameter	Condition	Value	Unit
Operating temperature	No dew condensation*8	+5 to +40	°C
Storage temperature	No dew condensation*8	-20 to +70	°C

\*8: When there is a temperature difference between a product and the surrounding area in high humidity environment, dew condensation may occur on the product surface. Dew condensation on the product may cause deterioration in characteristics and reliability.

Note: Exceeding the absolute maximum ratings even momentarily may cause a drop in product quality. Always be sure to use the product within the absolute maximum ratings.

**Spectral resolution vs. wavelength (typical example)**

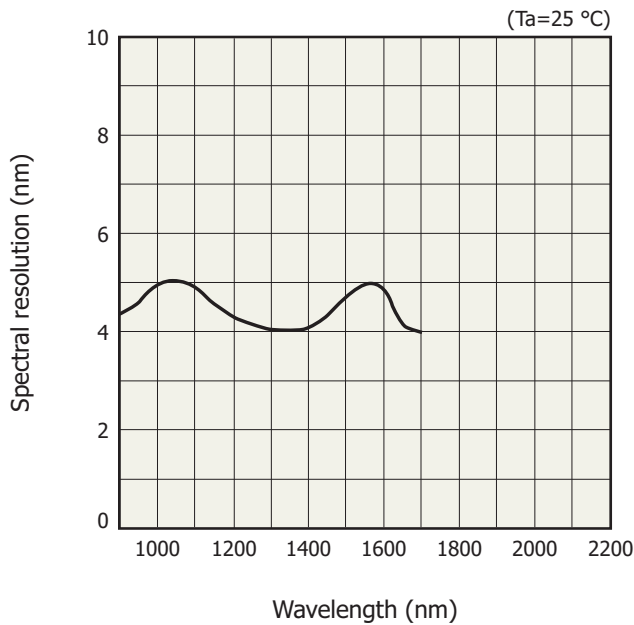

KACCB0262EA

**Linearity (typical example)**

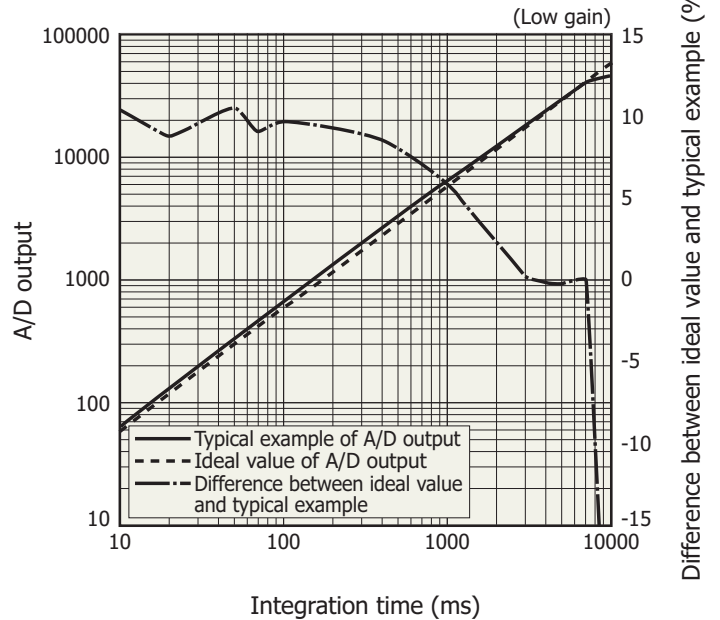

KACCB0250EA

A/D output is the output with dark output is subtracted when light is input. The difference between the ideal value and typical example contains a measurement error. The smaller the A/D output, the larger the measurement error.

### Dark output vs. ambient temperature (typical example)

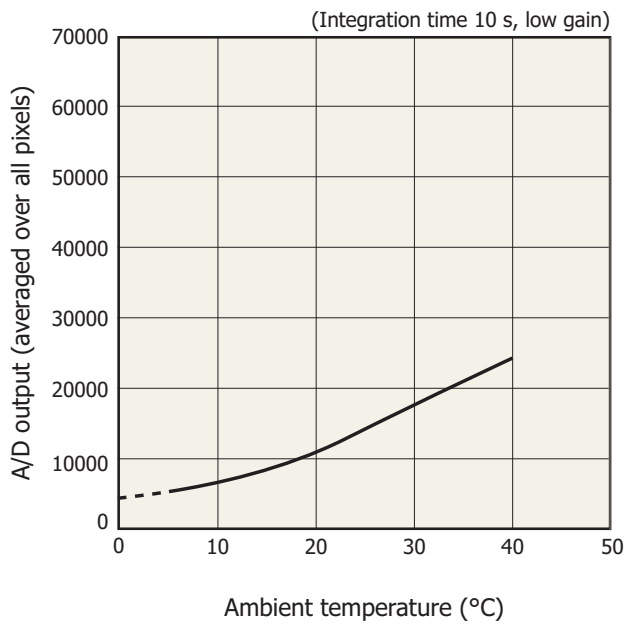

KACCB0253EA

A/D output is the sum of the sensor and circuit offset outputs and the sensor dark output.

### Optical component layout

The mini-spectrometer C11482GA uses a transmission holographic grating made of quartz and precision optical components arranged on a rugged optical base, making it possible to deliver high throughput and highly accurate optical characteristics.

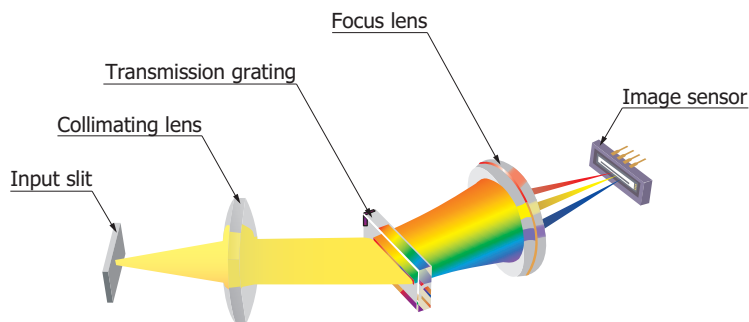

KACCC0256EA

### ❖ Connection example (transmission light measurement)

Light to be measured is guided into the entrance port of TG series through an optical fiber and the spectrum measured with the built-in image sensor is output through the USB port to a PC for data acquisition. There are no moving parts inside the unit so stable measurements are obtained at all times. An optical fiber that guides light input from external sources allows a flexible measurement setup.

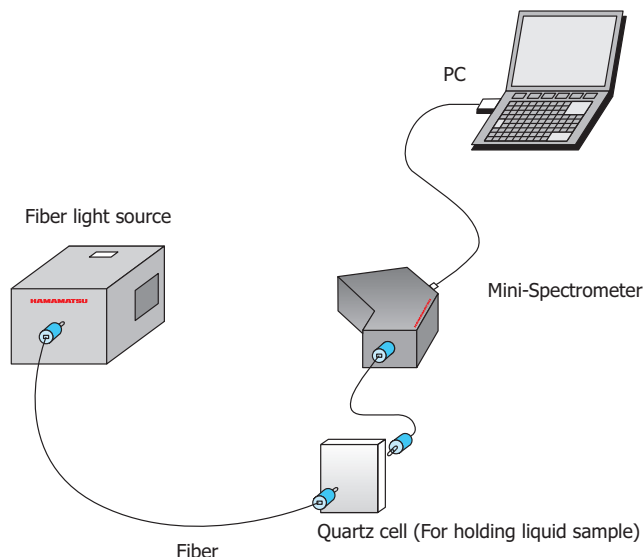

KACCC0689EA

### ❖ Evaluation software (supplied with unit)

Installing the evaluation software (SpecEvaluationUSB2.exe)\*9 into your PC allows running the following basic tasks:

- Measurement data acquisition and save
- Measurement condition setup
- Module information acquisition  
(wavelength conversion factor, polychromator type, etc.)
- Graphic display
- Arithmetic function
  - Pixel number to wavelength conversion
  - Comparison calculation with reference data  
(transmittance, reflectance)
  - Dark subtraction
  - Gaussian approximation  
(peak position and count, FWHM)

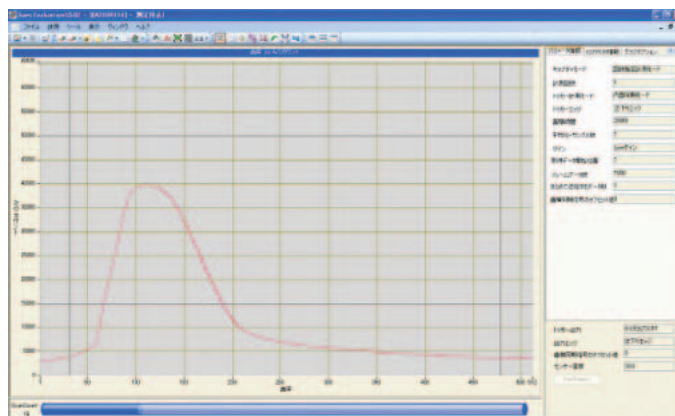

Note: Up to 8 mini-spectrometers can be connected and used with one PC.

\*9: Compatible OS: Microsoft® Windows® 7 Professional SP1 (32-bit, 64-bit)  
Microsoft® Windows® 8 Professional (32-bit, 64-bit)

DLL for controlling hardware is also provided.

You can develop your own measurement programs by using a following software development environment.

Microsoft® Visual Studio® 2008 (SP1) Visual C++®

Microsoft® Visual Studio® 2008 (SP1) Visual Basic®

Note: Microsoft, Windows, Visual Studio, Visual C++ and Visual Basic are either registered trademarks or trademarks of Microsoft Corporation in the United States and other countries.

**Measurement example**

Film thickness measurement (white light interferometry)

Thickness of 10 μm thick food wrapping film (polyvinylidene chloride) was measured.

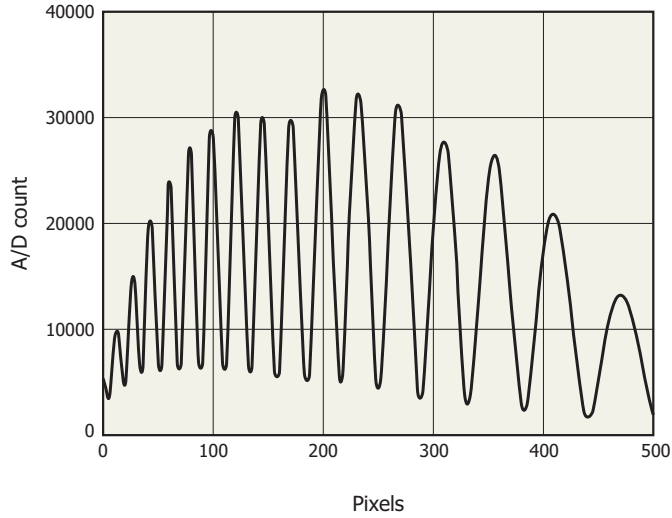

KACCB0095EA

Note:

Principle of film thickness measurement:

In film thickness measurement utilizing white light interferometry, an interference spectrum resulting from internal reflections between the front and back surfaces of a film is obtained.

The film thickness can then be determined by calculation from the spectral peak count, wavelength range, refractive index of film and incident light angle.

**Dimensional outline (unit: mm)**

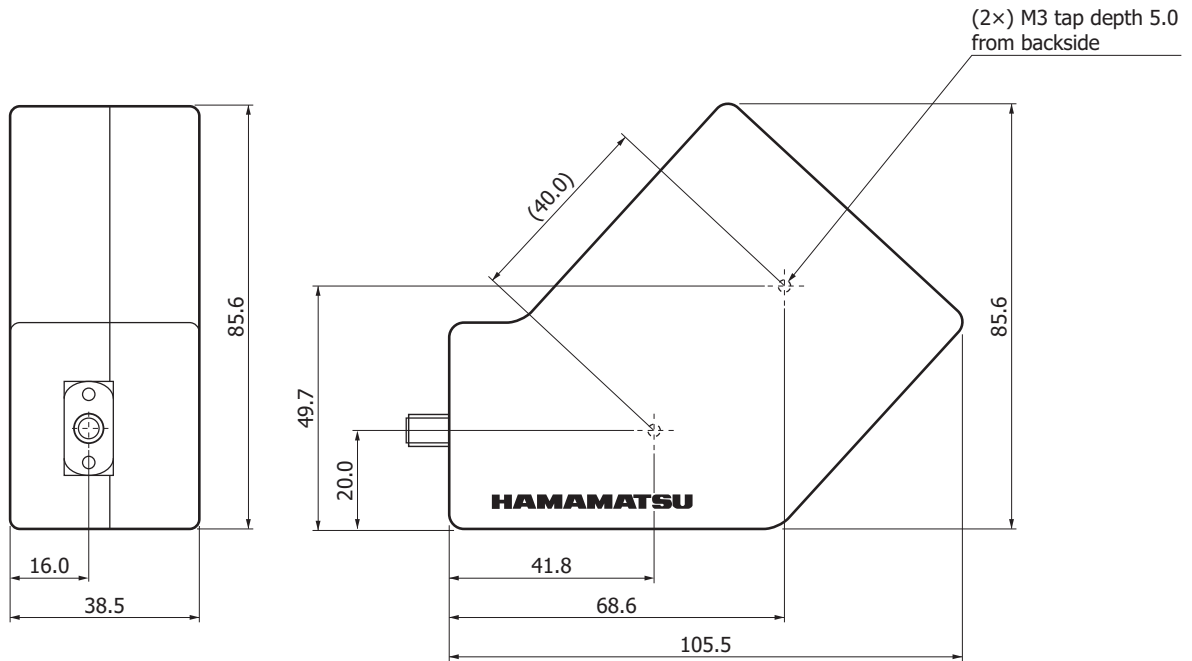

Tolerance unless otherwise noted: ±0.5  
Weight: 280 g

KACCA0146EE

### Accessories

- USB cable
- Dedicated software (evaluation software, sample software, DLL)

### Options (sold separately)

- Optical fiber for light input

Type no.	Product name	Applicable mini-spectrometer	Core diameter ( $\mu\text{m}$ )	Specification
A9763-01	Fiber for visible/near infrared range	C11482GA (TG2-NIR)	600	NA=0.22, length 1.5 m, connectorized SMA905D at both ends

- Coaxial cable for external trigger input A10670

Dimensional outline (unit: mm)

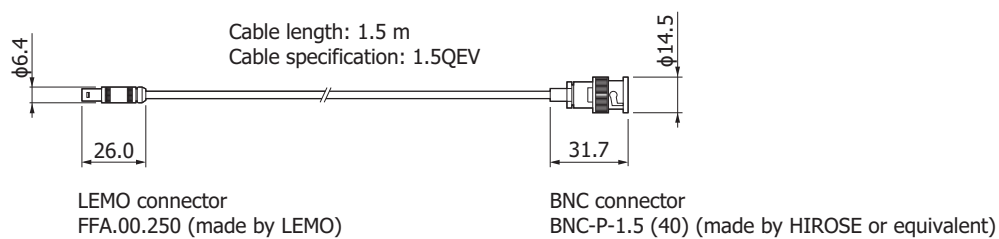

KACCA0220EB

Mini-spectrometer lineup

Type no.	Type	Spectral response range (nm)													Spectral resolution max. (nm)	Image sensor			
		200	400	600	800	1000	1200	1400	1600	1800	2000	2200	2400	2600					
C10082CA	TM-UV/VIS-CCD High sensitivity																	6	Back-thinned CCD image sensor
C10082CAH	TM-UV/VIS-CCD High resolution		200 to 800															1*	
C10082MD	TM-UV/VIS-MOS Wide dynamic range																	6	CMOS linear image sensor
C10083CA	TM-VIS/NIR-CCD High sensitivity																	8 (λ=320 to 900 nm)	Back-thinned CCD image sensor
C10083CAH	TM-VIS/NIR-CCD High resolution																	1* (λ=320 to 900 nm)	
C10083MD	TM-VIS/NIR-MOS Wide dynamic range																	8	CMOS linear image sensor
C11697MB	TM-VIS/NIR-MOS-II Trigger-compatible																	8	High-sensitivity CMOS linear image sensor
C9404CA	TG-UV-CCD High sensitivity		200 to 400															3	Back-thinned CCD image sensor
C9404CAH	TG-UV-CCD High resolution		200 to 400															1*	
C9405CB	TG-SWNIR-CCD-II IR-enhanced																	5 (λ=550 to 900 nm)	IR-enhanced back-thinned CCD image sensor
C11713CA	TG-RAMAN-I High resolution																	0.3*	Back-thinned CCD image sensor
C11714CB	TG-RAMAN-II High resolution																	0.3*	IR-enhanced back-thinned CCD image sensor
C11482GA	TG2-NIR Non-cooled type																	7	InGaAs linear image sensor
C9913GC	TG-cooled NIR-I Low noise (cooled type)																	7	
C9914GB	TG-cooled NIR-II Low noise (cooled type)																	8	
C11118GA	TG-cooled NIR-III Low noise (cooled type)																	20	
C13053MA	TF-SWIR-MOS-II Compact, thin case																	3.5	High-sensitivity CMOS linear image sensor
C13054MA	TF-RAMAN Compact, thin case																	0.4*	
C13555MA	TF-VIS-MOS-II Compact, thin case																	3	
C11007MA	RC-VIS-MOS Spectrometer module																	9	CMOS linear image sensor
C11008MA	RC-SWNIR-MOS Spectrometer module																	8	IR-enhanced CMOS linear image sensor

\* Typ.

For installation into mobile measuring equipment

Type no.	Type	Spectral response range (nm)													Spectral resolution max. (nm)	Image sensor			
		200	400	600	800	1000	1200	1400	1600	1800	2000	2200	2400	2600					
C11009MA	RC-VIS-MOS Spectrometer head																	9	CMOS linear image sensor
C11010MA	RC-SWNIR-MOS Spectrometer head																	8	IR-enhanced CMOS linear image sensor

For installation into mobile measuring equipment (ultra-compact)

Type no.	Type	Spectral response range (nm)													Spectral resolution max. (nm)	Image sensor			
		200	400	600	800	1000	1200	1400	1600	1800	2000	2200	2400	2600					
C11708MA	MS-SWNIR-MOS Spectrometer head																	20	CMOS linear image sensor
C12666MA	Spectrometer head																	15	CMOS linear image sensor
C12880MA	Spectrometer head																	15	High-sensitivity CMOS linear image sensor

## Related information

[http://www.hamamatsu.com/sp/ssd/doc\\_en.html](http://www.hamamatsu.com/sp/ssd/doc_en.html)

### ■ Precautions

- Disclaimer
- Mini-spectrometers

### ■ Technical information

- Mini-spectrometers

Information described in this material is current as of February 2016.

Product specifications are subject to change without prior notice due to improvements or other reasons. This document has been carefully prepared and the information contained is believed to be accurate. In rare cases, however, there may be inaccuracies such as text errors. Before using these products, always contact us for the delivery specification sheet to check the latest specifications.

The product warranty is valid for one year after delivery and is limited to product repair or replacement for defects discovered and reported to us within that one year period. However, even if within the warranty period we accept absolutely no liability for any loss caused by natural disasters or improper product use. Copying or reprinting the contents described in this material in whole or in part is prohibited without our prior permission.

# HAMAMATSU

[www.hamamatsu.com](http://www.hamamatsu.com)

HAMAMATSU PHOTONICS K.K., Solid State Division

1126-1 Ichino-cho, Higashi-ku, Hamamatsu City, 435-8558 Japan, Telephone: (81) 53-434-3311, Fax: (81) 53-434-5184

U.S.A.: Hamamatsu Corporation: 360 Foothill Road, Bridgewater, N.J. 08807, U.S.A., Telephone: (1) 908-231-0960, Fax: (1) 908-231-1218

Germany: Hamamatsu Photonics Deutschland GmbH: Arzbergerstr. 10, D-82211 Herrsching am Ammersee, Germany, Telephone: (49) 8152-375-0, Fax: (49) 8152-265-8

France: Hamamatsu Photonics France S.A.R.L.: 19, Rue du Saule Trapu, Parc du Moulin de Massy, 91882 Massy Cedex, France, Telephone: 33-(1) 69 53 71 00, Fax: 33-(1) 69 53 71 10

United Kingdom: Hamamatsu Photonics UK Limited: 2 Howard Court, 10 Tewin Road, Welwyn Garden City, Hertfordshire AL7 1BW, United Kingdom, Telephone: (44) 1707-294888, Fax: (44) 1707-325777

North Europe: Hamamatsu Photonics Norden AB: Torshamnsgatan 35 16440 Kista, Sweden, Telephone: (46) 8-509-031-00, Fax: (46) 8-509-031-01

Italy: Hamamatsu Photonics Italia S.r.l.: Strada della Moia, 1 int. 6, 20020 Arese (Milano), Italy, Telephone: (39) 02-93581733, Fax: (39) 02-93581741

China: Hamamatsu Photonics (China) Co., Ltd.: B1201, Jiaming Center, No.27 Dongsanhuan Beilu, Chaoyang District, Beijing 100020, China, Telephone: (86) 10-6586-6006, Fax: (86) 10-6586-2866