

Features

Supports the Hamamatsu S13361-3050AE-04
4x4 array of 3mm SiPMs

Compatible with AiT Passive Base Amplifiers
PBA116 and PBA216

Bias circuit only, no amplifiers

Precision temperature sensor

Mounting holes for #4 or M3 hardware

Several standard versions are available
Contact us for customization

Specifications

Bias Voltage

Voltage clamp 68V Zener diode
 375mW maximum

Temperature Sensor

Output voltage 500mV + 10mV per degree C
Output current 10mA
Output impedance 100Ω
Accuracy ±0.5°C
Voltage requirements +VA = +2.5V → +5.5V, < 1mA
 -VA = not connected

Mating cable assembly

Samtec FFSD-20-D-XX.XX-01-N
XX.XX = length in inches

Part Number: PB16 {V/H} {F/B} {R}

V = Vertical latch/eject connector
H = Horizontal unshrouded connector
F = Connector located on the front
B = Connector located on the back
R = Reverse connector orientation

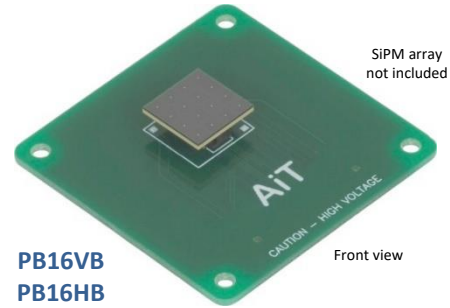

PB16VB
PB16HB

Front view

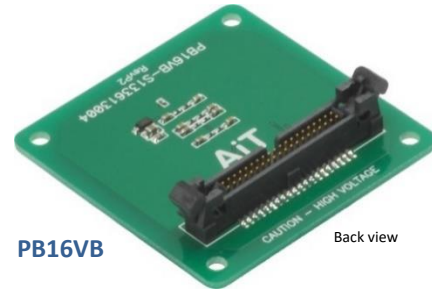

PB16VB

Back view



PB16HB

Back view

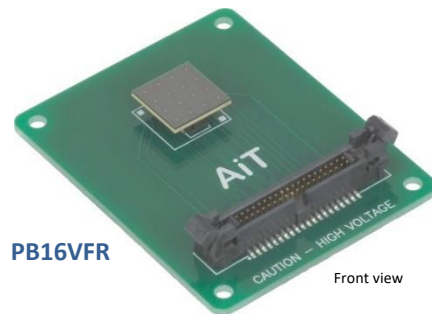

PB16VFR

Front view

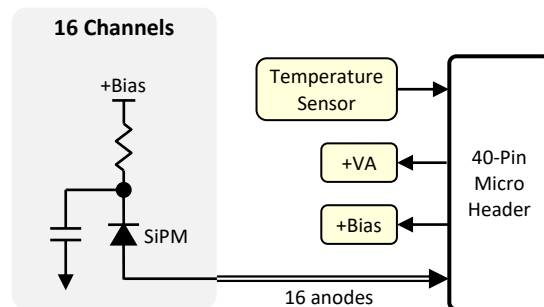

Standard Connector Options

Shown attached to the PBA116 with a 50.8mm (2") FFSD cable

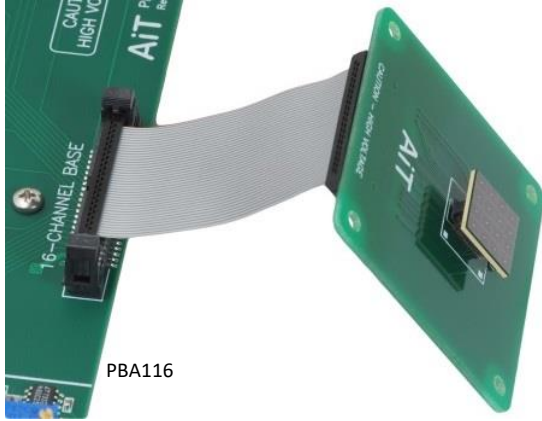

PB16HB

Horizontal unshrouded connector on the back with standard pin-1 position.

Lowest vertical profile of the attached base.

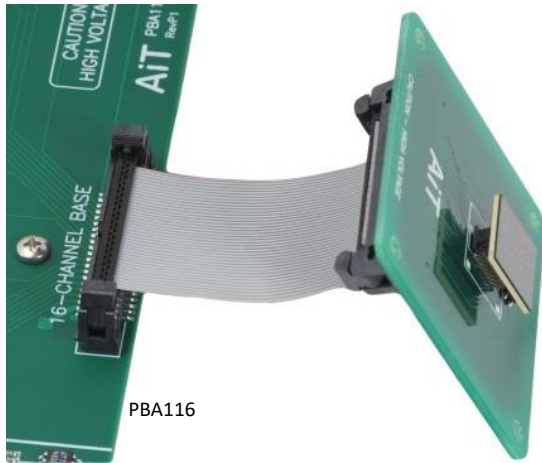

PB16VB

Vertical shrouded latch-eject connector on the back with standard pin-1 position.

Identical to the PB16HB except a vertical latch-eject connector replaces the horizontal connector to securely latch the cable in place, preventing accidental connector misalignment or disconnection.

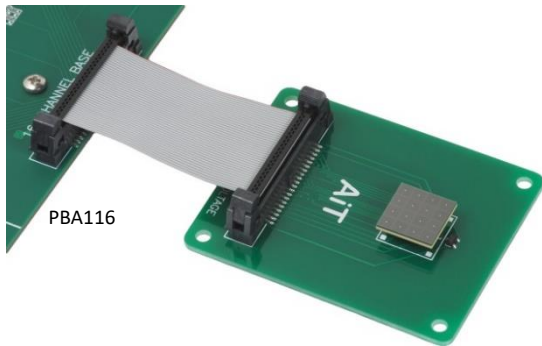

PB16VFR

Vertical latch-eject connector on the front with reversed pin-1 position.

Permits placement of the passive base side-by-side with the PBA, facing upward.

*Includes four standoffs with #4-40 screws.

16-Channel Passive Base Readout Kit

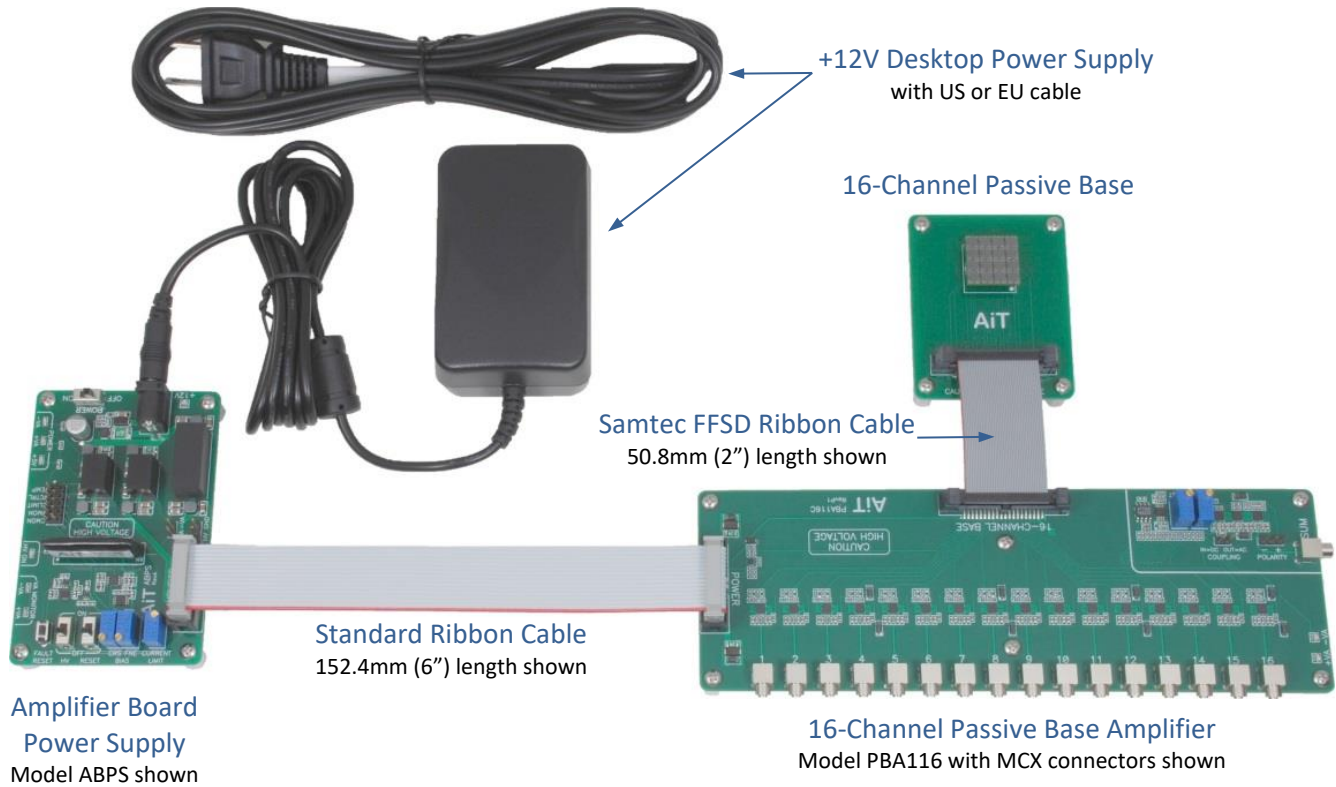

Components

Each component is available separately. Refer to each datasheet for details.

No accessories are included with the Passive Base.

The Amplifier Board Power Supply includes a 12V desktop power supply and a HV80 bias voltage power supply.

The 16-channel Passive Base Amplifier includes a FFSD cable to connect the passive base, a power supply ribbon cable, and a breakout board to connect any external power supply.

Typical Signals

Transimpedance amplifier, 500Ω gain

Source = Laser; PBA116 channel 1; Bias = +56V; FFSD cable length = 50.8mm (2"); Rise time = minimum

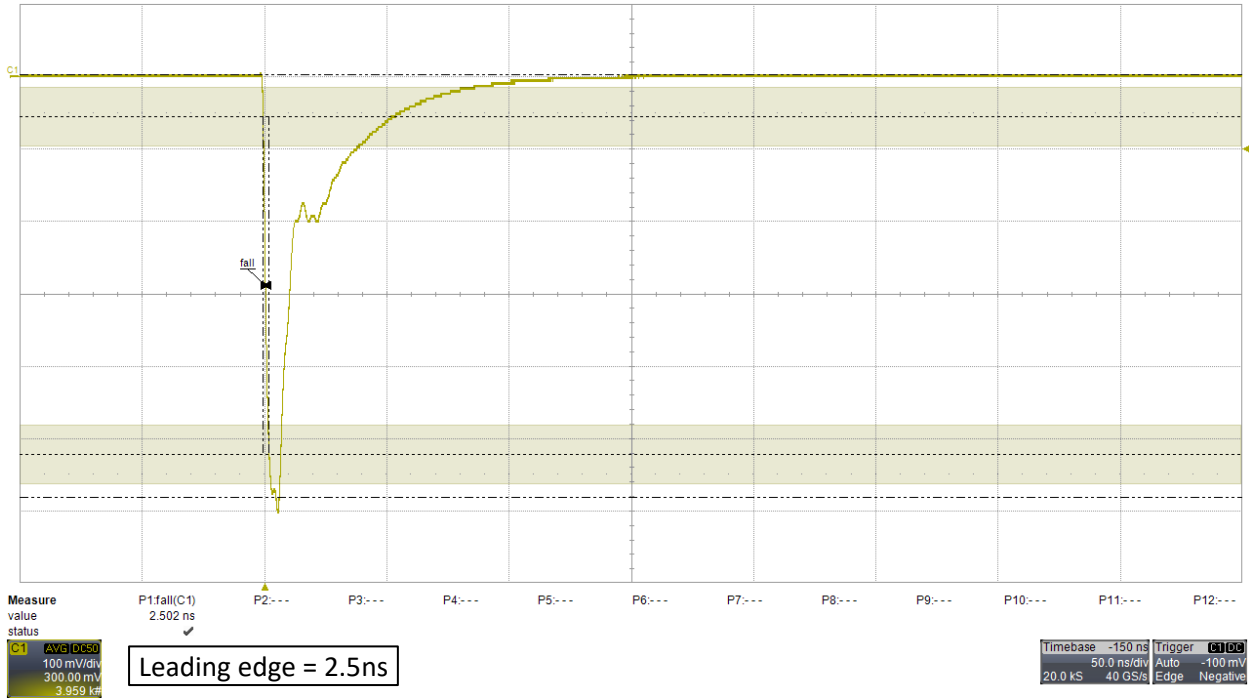

Source = LYSO emission; PBA116 channel 8; Bias = +56V; FFSD cable length = 50.8mm (2"); Signal persistence

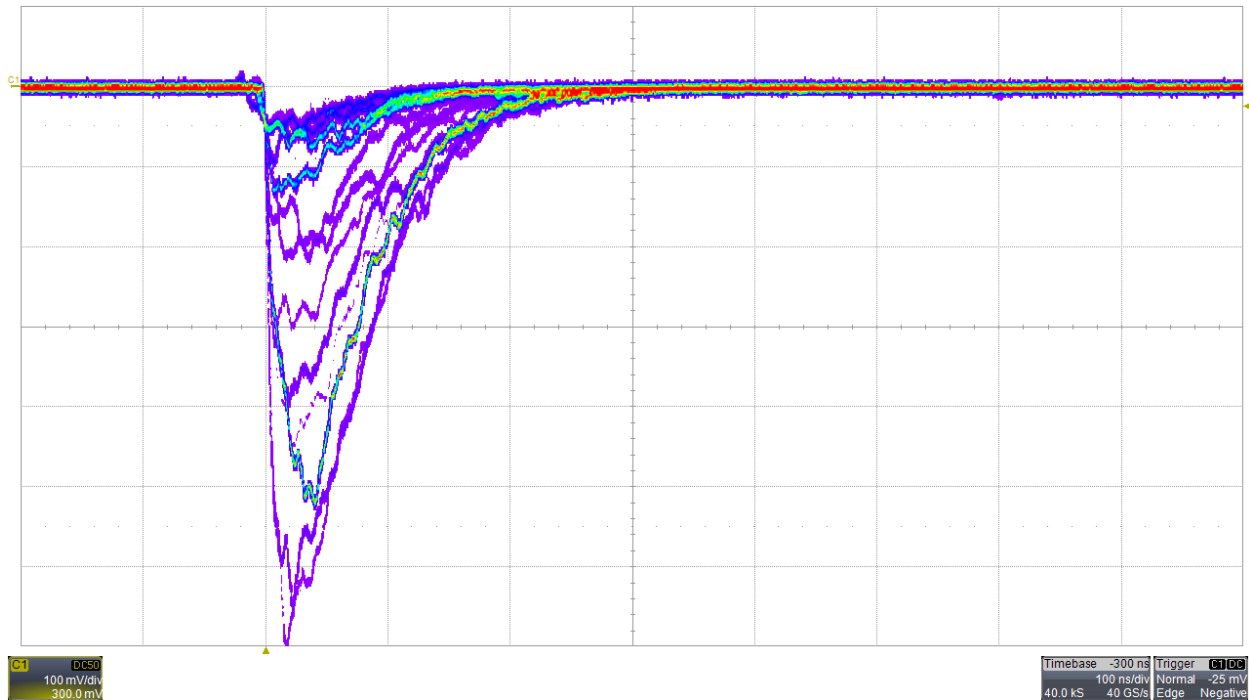

Long signal rise times with long cables (PBA116 channel 1, Bias=+56V)

Source = Laser; FFSD cable length = 152.4mm (6"); Rise time = 6ns

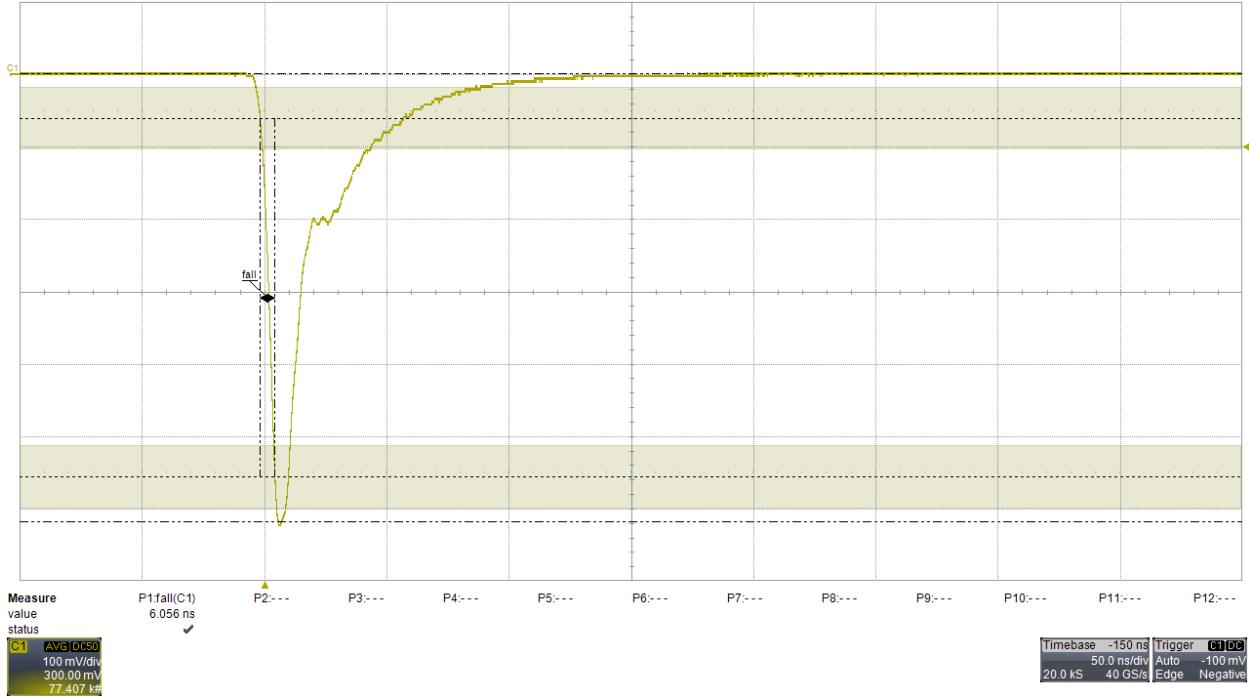

Source = Laser; FFSD cable length = 304.8mm (12"); Rise time = 12ns

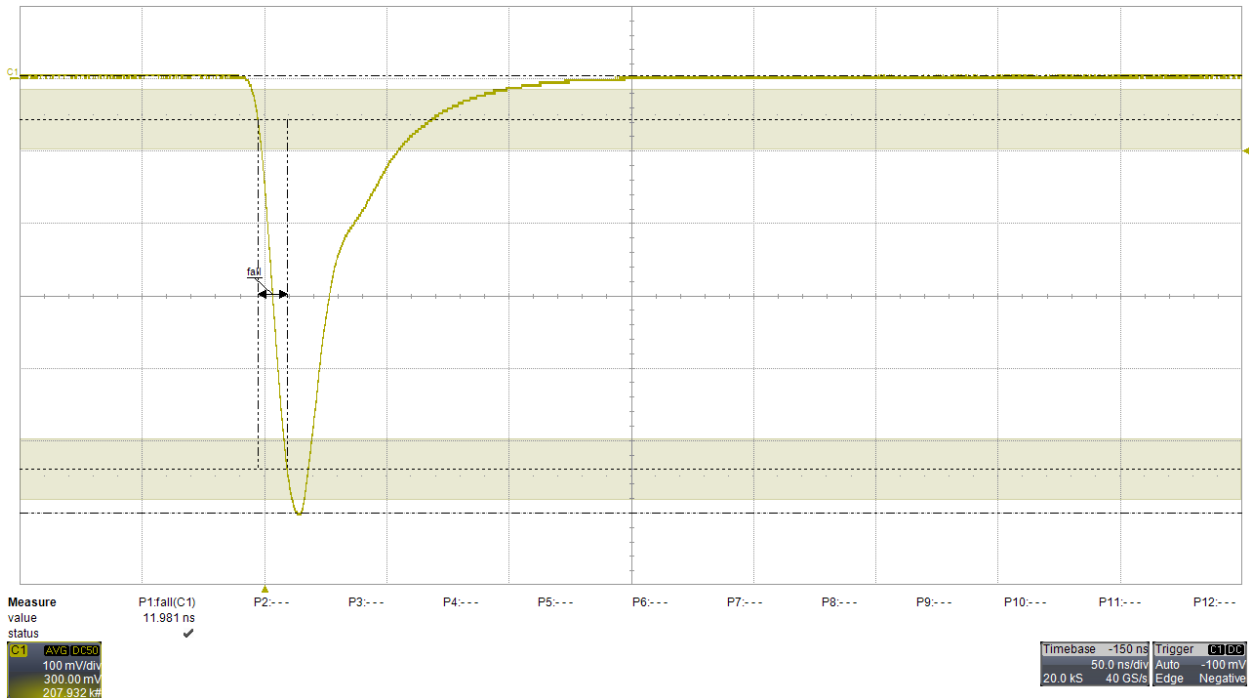

Short signal rise times with long cables (PBA116 channel 1, Bias=+56V)

Source = Laser; FFSD cable length = 152.4mm (6"); Rise time = minimum

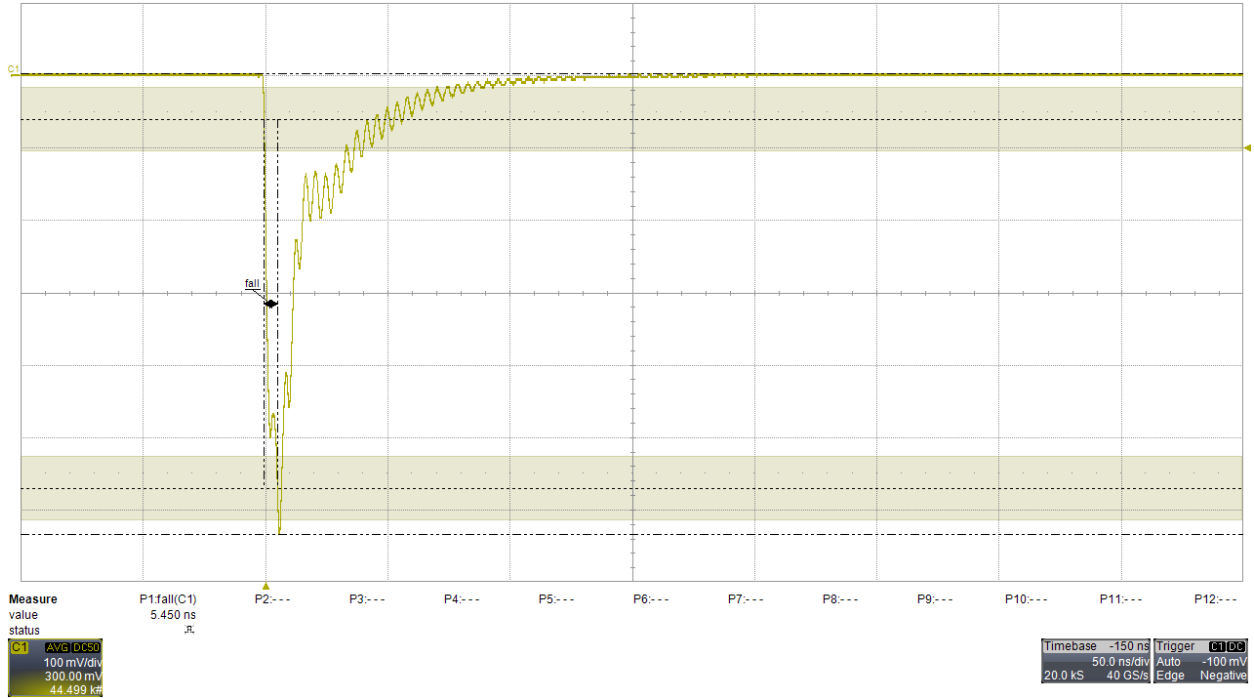

Source = Laser; FFSD cable length = 304.8mm (12"); Rise time = 6ns

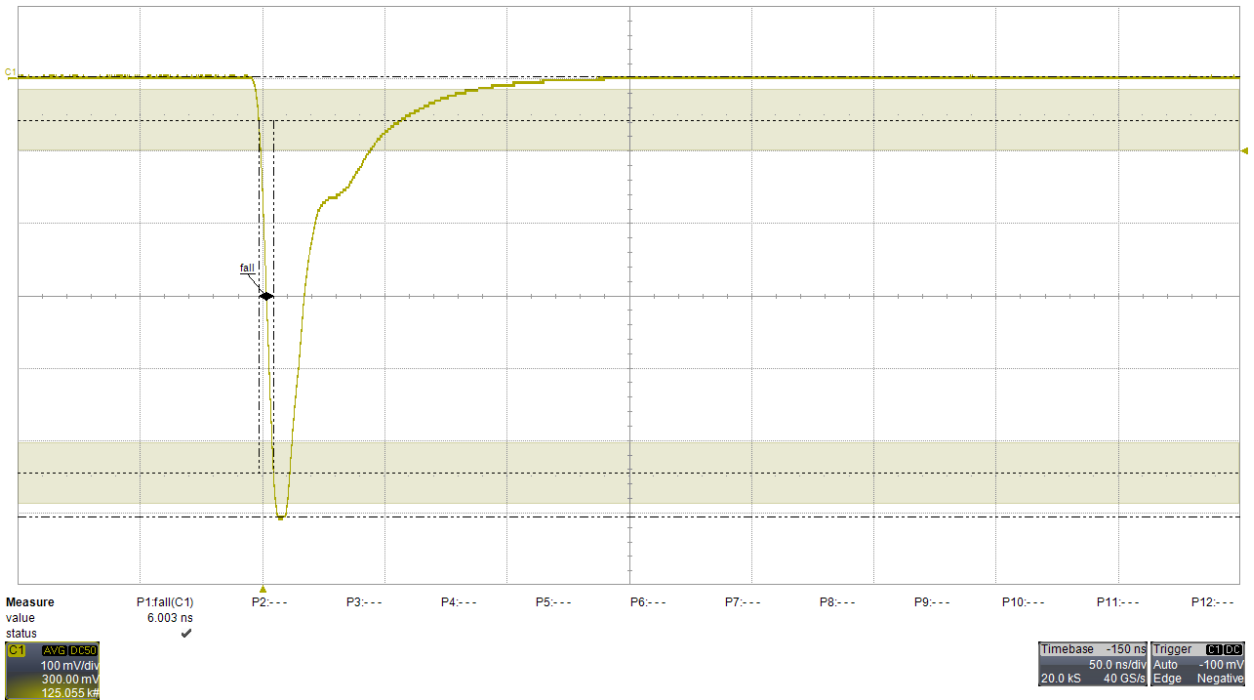

Typical Signals

Voltage amplifier, 50Ω input impedance, x10 gain

Source = Laser; PBA116 channel 1; Bias = +56V; FFSD cable length = 50.8mm (2"); Rise time = minimum

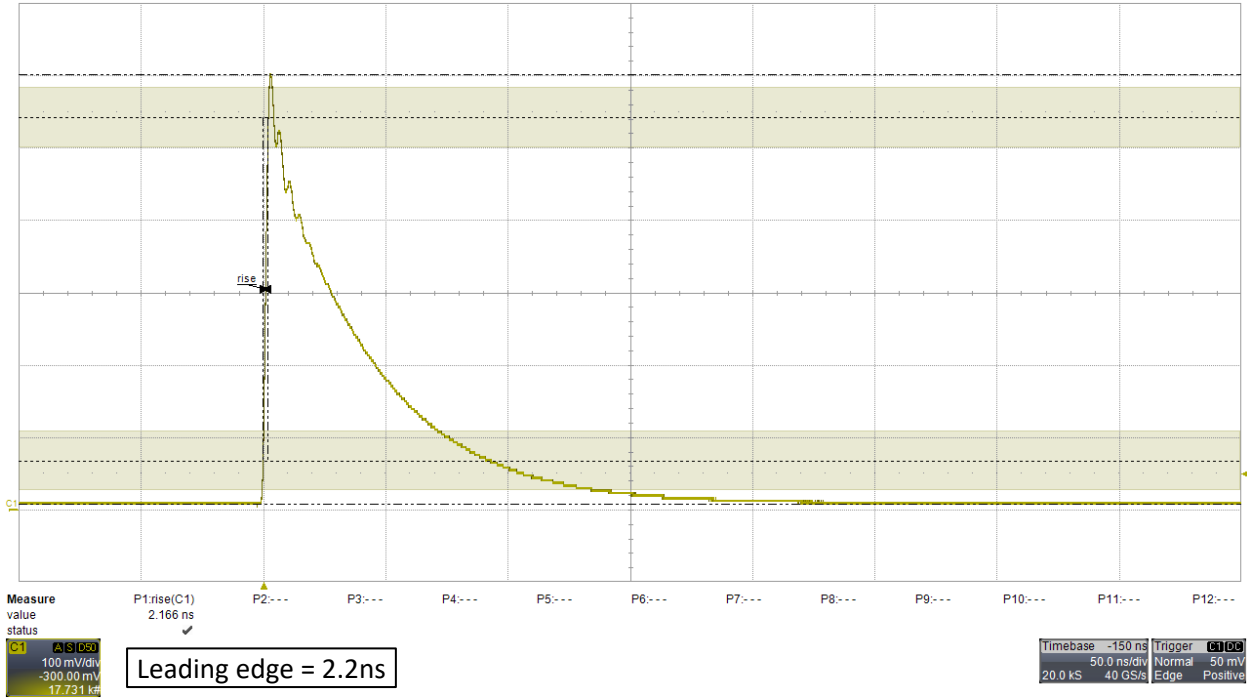

Source = LYSO emission; PBA116 channel 1; Bias = +56V; FFSD cable length = 50.8mm (2"); Signal persistence

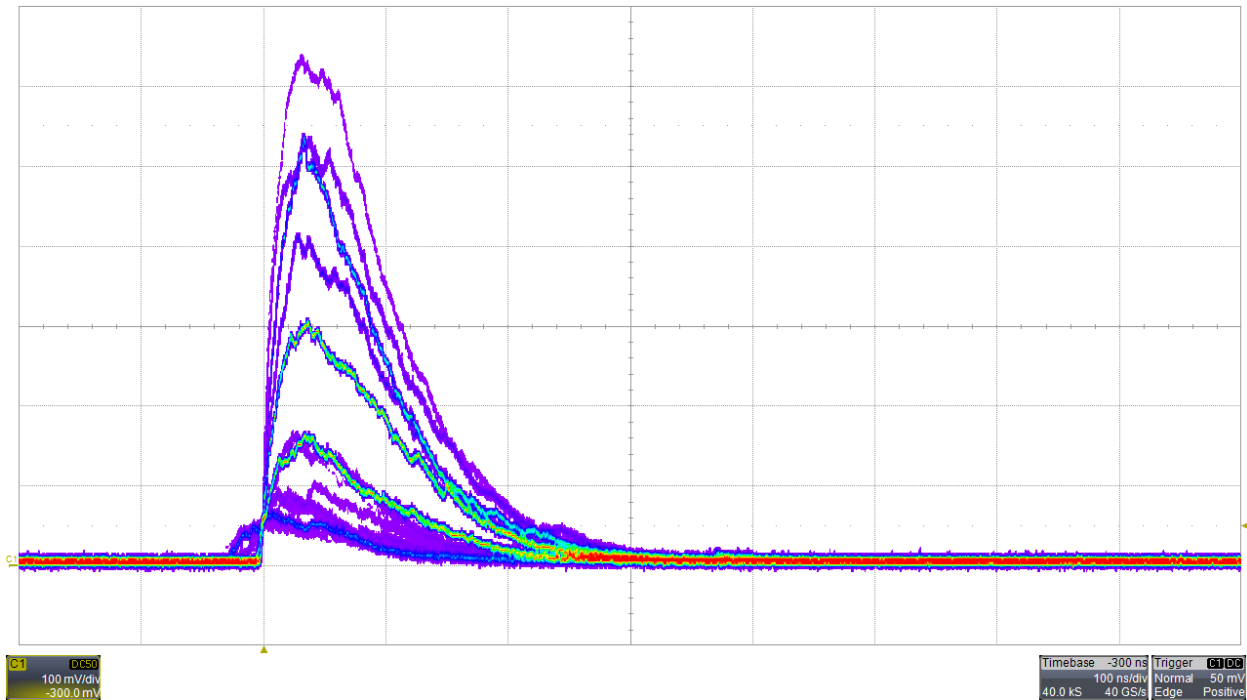

Long signal rise times with long cables (PBA116 channel 1, Bias=+56V)

Source = Laser; FFSD cable length = 152.4mm (6"); Rise time = 6ns

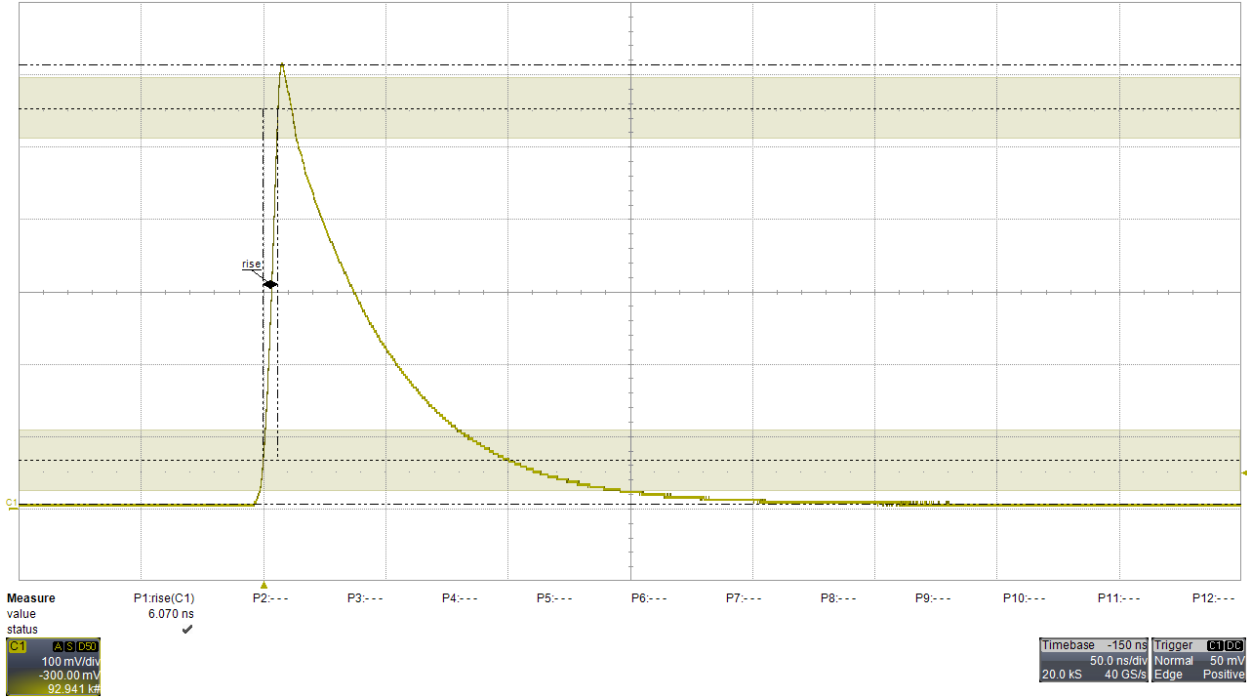

Source = Laser; FFSD cable length = 304.8mm (12"); Rise time = 12ns

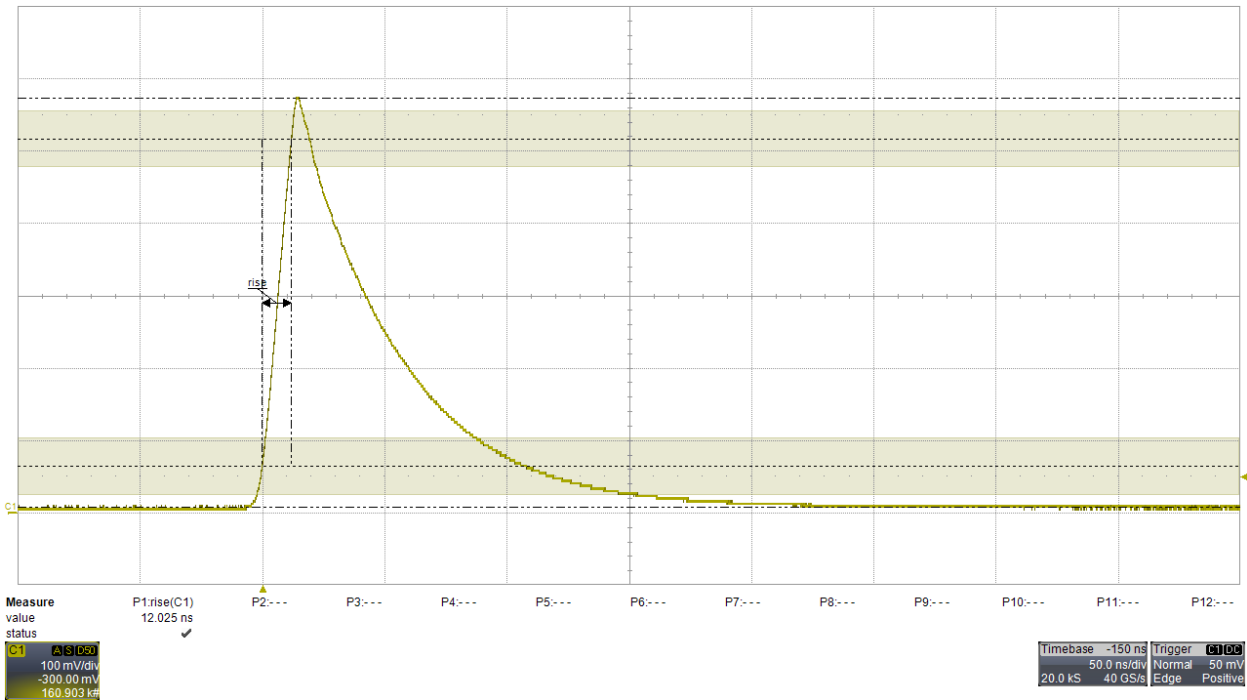

Short signal rise times with long cables (PBA116 channel 1, Bias=+56V)

Source = Laser; FFSD cable length = 152.4mm (6"); Rise time = minimum

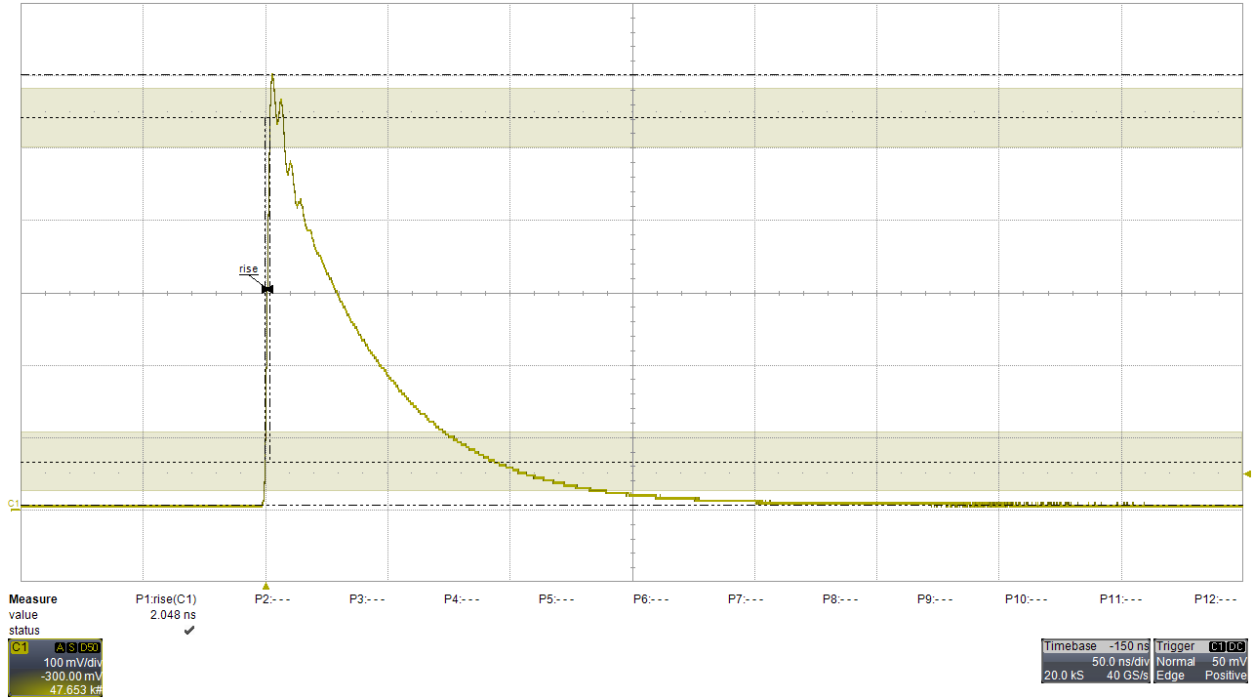

Source = Laser; FFSD cable length = 304.8mm (12"); Rise time = 6ns

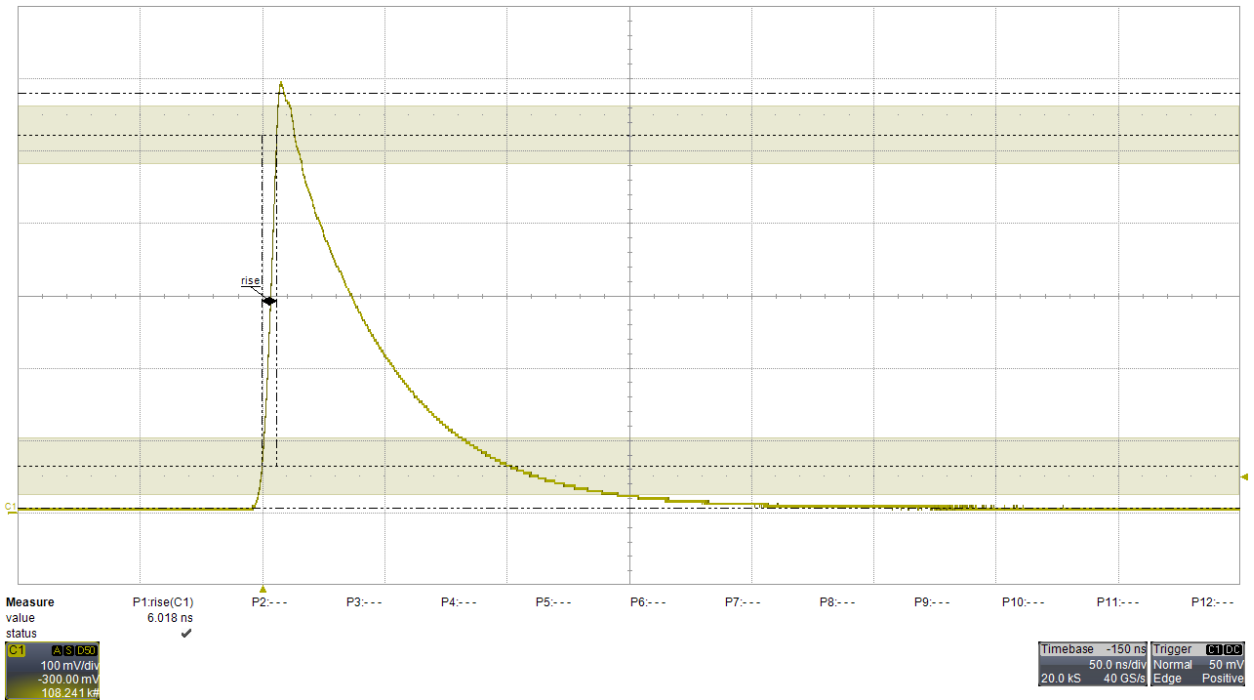

Mechanical

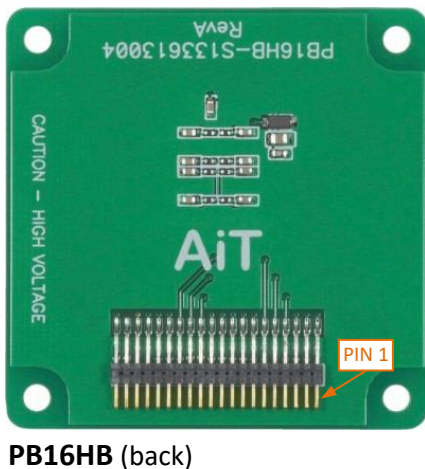
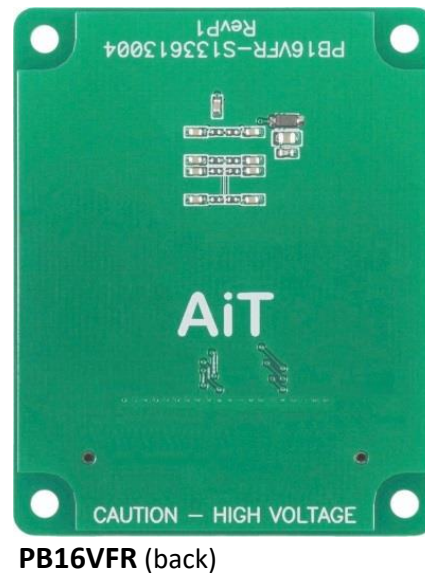
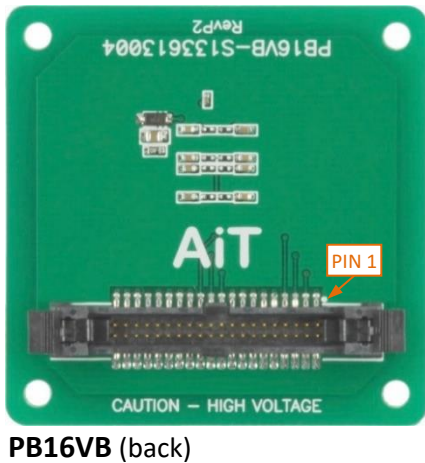
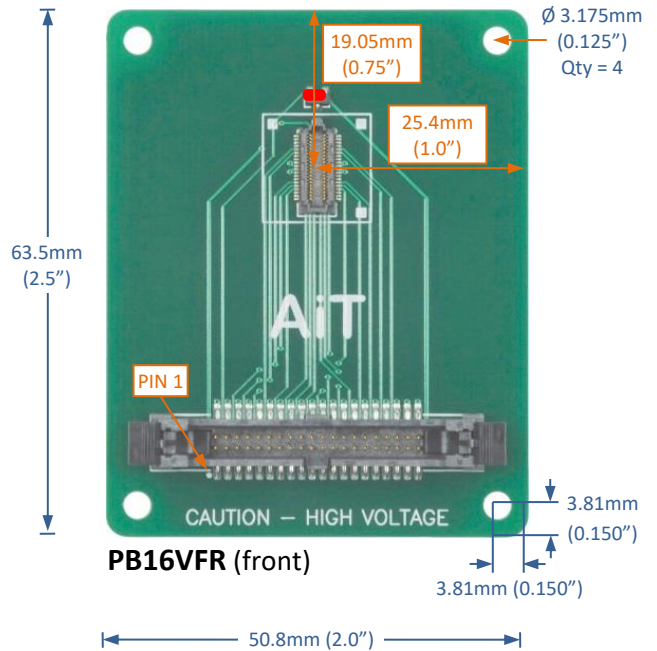
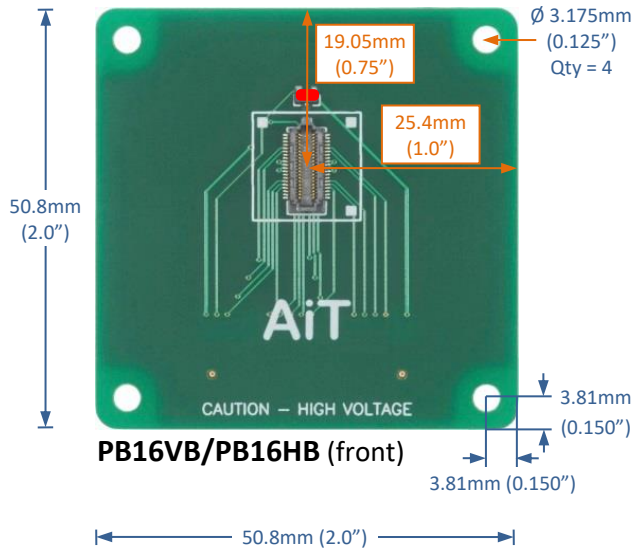

NOTES

- Temperature sensor

Align pin 1 with the red conductor on the Samtec FFSD ribbon cable

Measurement tolerance: ±0.020"

Signal Connector

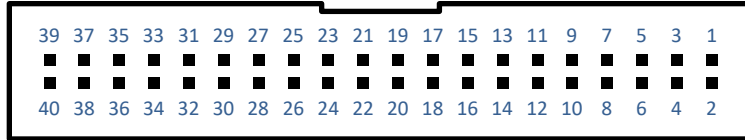

40-pin 0.050" header

Channel Map

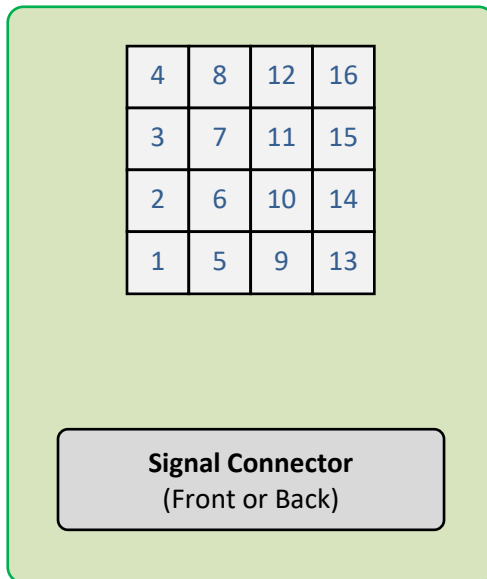

Pin	Function	Pin	Function
1	Bias	2	Ground
3	Temperature	4	Ground
5	Anode 1	6	Ground
7	Anode 2	8	Ground
9	Anode 3	10	Ground
11	Anode 4	12	Ground
13	Anode 5	14	Ground
15	Anode 6	16	Ground
17	Anode 7	18	Ground
19	Anode 8	20	Ground
21	Anode 9	22	Ground
23	Anode 10	24	Ground
25	Anode 11	26	Ground
27	Anode 12	28	Ground
29	Anode 13	30	Ground
31	Anode 14	32	Ground
33	Anode 15	34	Ground
35	Anode 16	36	Ground
37	-VA	38	Ground
39	+VA	40	Ground

Safety Information



WARNING – High Voltage

- High voltage may be present during operation
- High voltage stored on capacitors may be present after power is removed
- Improper handling may result in personnel injury or equipment damage

This high-voltage device must be used only by personnel trained and qualified in safe handling, installation, and operation of high-voltage equipment.



CAUTION – Electrostatic Discharge (ESD) Sensitivity

The circuit board can be damaged by electrostatic discharge. Observe precautions for handling electrostatic sensitive devices. Handle only at static-safe workstations.

High-Gain Photodetectors

High-gain photodetectors such as silicon photomultipliers may conduct damaging currents if exposed to high optical signal levels while the bias voltage is applied, or if the bias voltage exceeds the recommended operating range. These devices must be operated only in low-light conditions, and only within the manufacturer's recommended bias voltage range.

Handling and Disassembly

This product may be provided with a protective enclosure. Disassembled enclosure components and circuit boards may contain sharp edges. Take appropriate safety precautions while assembling or disassembling the enclosure and handling disassembled components.

Indoor Use Only

Do not operate this product in a wet or damp environment. Do not operate in an explosive atmosphere.

Use of this product, and AiT Instruments' liability related to use of this product, is further governed by AiT Instruments' standard terms and conditions of sale, which were provided upon purchase of this product.