

InGaAs APD

G8931-20

Large active area: $\phi 0.2$ mm, high-speed response: 0.9 GHz

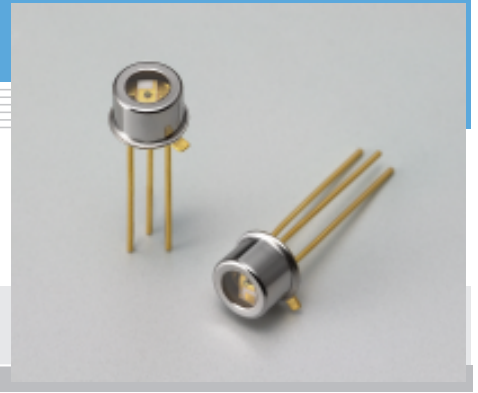

G8931-20 is a large area InGaAs APD designed for distance measurement, spatial light transmission and low-light-level detection, etc. Despite its large active area of $\phi 0.2$ mm, G8931-20 provides high-speed response (typical cut-off frequency 0.9 GHz at M=10).

Features

- Active area: $\phi 0.2$ mm
- Low voltage operation
- Low capacitance
- High sensitivity
- Low dark current

Applications

- Distance measurement
- Spatial light transmission
- OTDR
- Low-light-level detection

General ratings

Parameter	Symbol	Value	Unit
Active area	-	$\phi 0.2$	mm

Absolute maximum ratings

Parameter	Symbol	Value	Unit
Forward current	I _F	2	mA
Reverse current	I _R	2	mA
Operating temperature	T _{opr}	-40 to +85	°C
Storage temperature	T _{stg}	-55 to +125	°C

Electrical and optical characteristics (T_a=25 °C)

Parameter	Symbol	Condition	Min.	Typ.	Max.	Unit
Spectral response range	λ		-	0.95 to 1.7	-	μm
Peak sensitivity wavelength	λ_p		-	1.55	-	μm
Photo sensitivity	S	$\lambda = 1.55 \mu\text{m}$, M=1	0.8	0.9	-	A/W
Breakdown voltage	V _{BR}	I _D =100 μA	40	-	60	V
Temperature coefficient of V _{BR}	Γ	-40 to +85 °C	-	0.11	0.16	V/°C
Dark current	I _D	V _R =V _{BR} × 0.9	-	150	200	nA
Cut-off frequency	f _c	M=10	0.6	0.9	-	GHz
Terminal capacitance	C _t	V _R =V _{BR} × 0.9 f=1 MHz	-	1.5	2	pF

Spectral response

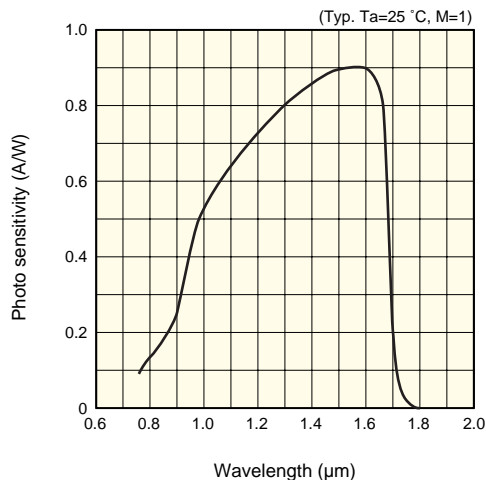

KAPDB0120EA

Dark current vs. reverse voltage

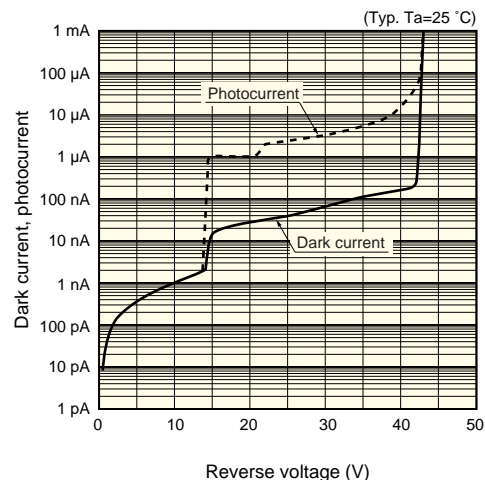

KAPDB0121EA

SOLID STATE DIVISION

■ Terminal capacitance vs. reverse voltage

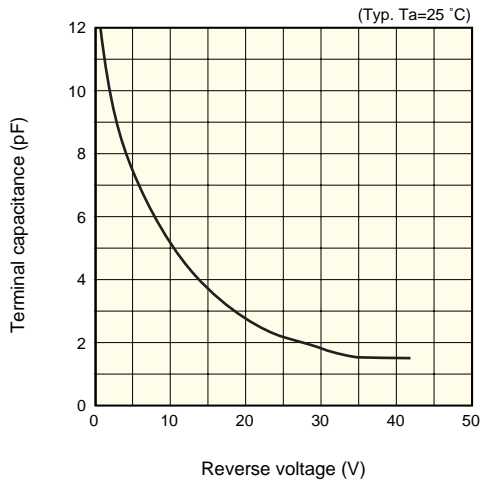

KAPDB0122EA

■ Dimensional outline (unit: mm)

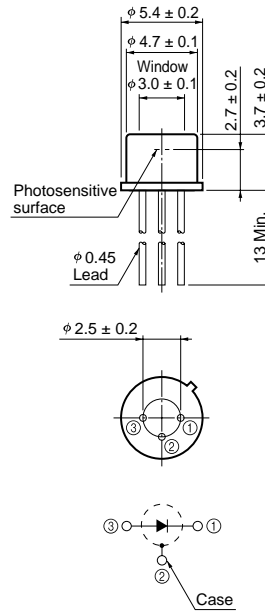

KAPDA0034EA

■ Peripheral circuit example of APD

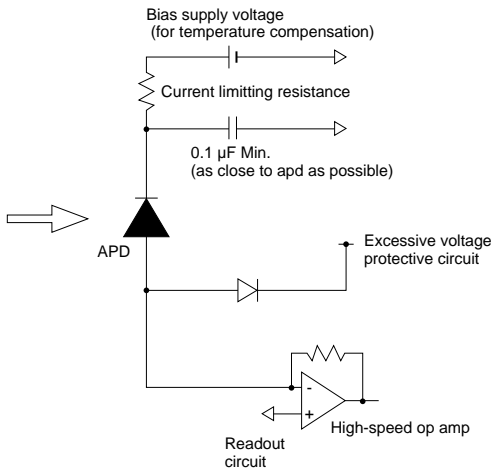

KAPDC0005EC